

A-ONE 工具系统(三)

--用于线切割

深圳市精钻智能制造有限公司

地址: 深圳市光明区马田街道石围社区石围大田洋工业区1号A栋101

电话: 86-755-27296210 27296211 27296212

传真: 86-755-27296213

Q Q: 879429227

全国服务热线: 400-880-9912

ShenZhen JingZuan Intelligent Manufacturing CO.,LTD

Add: No. 101, Building A, Shiwei Datianyang Industrial Area, Matian Ave,
Guangming Area, Shenzhen

TEL: 86-755-27296210 27296211 27296212

FAX: 86-755-27296213

Q Q: 879429227

Hotline: +86 400-880-9912

苏州市精钻智能制造有限责任公司

SuZhou Jingzuan Intelligent Manufacturing Co.,LTD

苏州市相城区望亭镇何家角村杭桥路3号

ADD: No. 3, Hangqiao Road, Hejiajiao Village, Wangting Town, Xiangcheng Area, Suzhou

电话 (TEL): 0512-6575 1221

传真 (FAX): 0512-6575 1222



A-ONE中文网站



A-ONE英文网站

开本: 210*285
版本: 2023-09
数量: 1000
编号: SZJZ-3A03

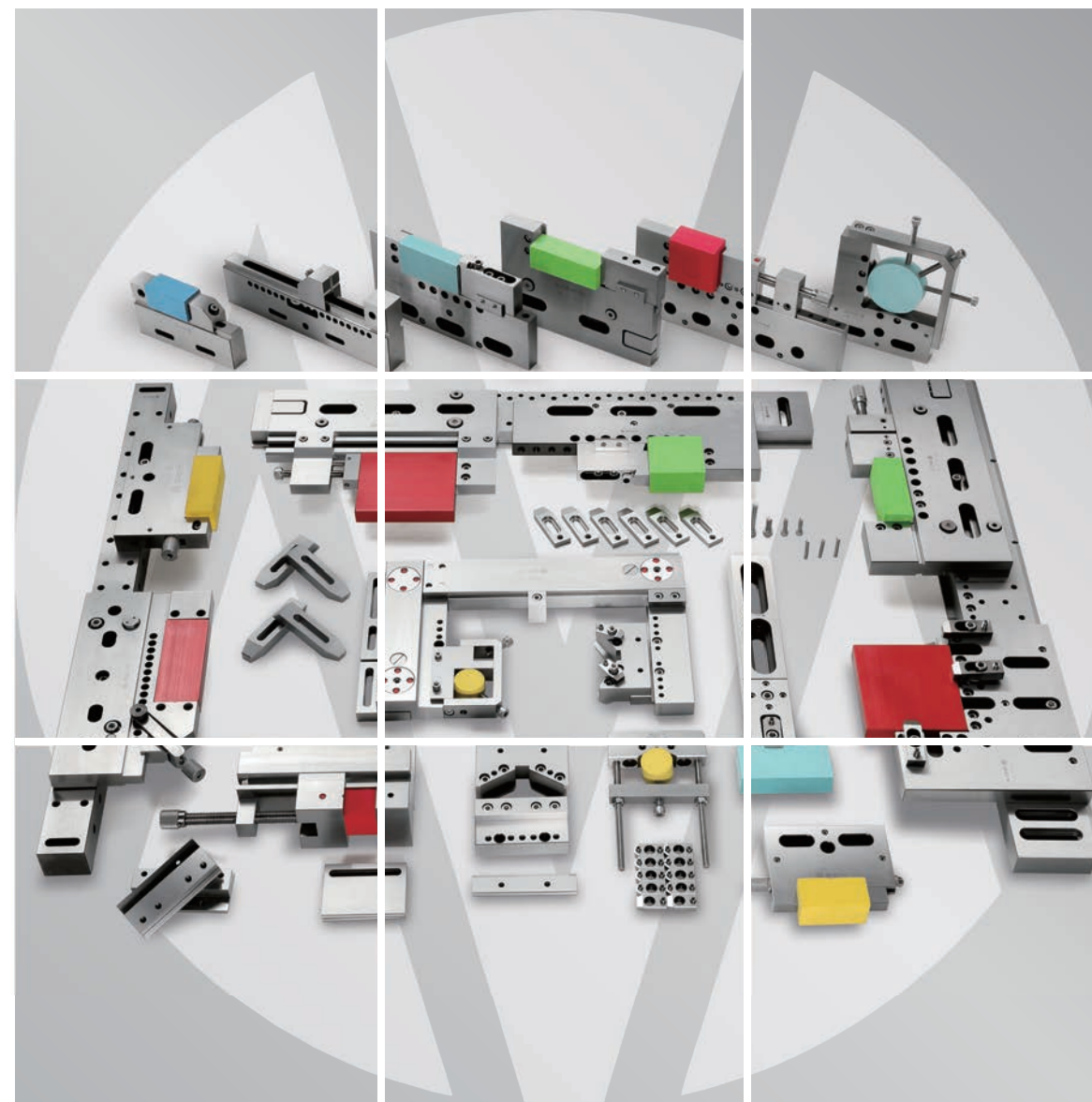

★ Final interpretation of all contents, text in the picture and text are for reference only, actual product, subject to change without notice. Please call +86 755 27296210/6211/6212.

★ 本画册最终解释权归本公司所有, 文中图片及文字仅供参考, 产品以实物为准, 如有变更, 恕不另行通知, 详情请致电 0755-27296210/6211/6212

★ 版权所有 翻版必究

E-mail: zgx@szjztools.com

Http://www.szjztools.com

Http://www.system3a.com

A-ONE

公司简介

深圳市精钻智能制造有限公司自2000年成立以来，秉承“精益求精，钻石服务”的经营理念，不断引进先进的设备及技术，生产高品质、稳定可靠的产品，为客户创造更多价值。现有牧野(MAKINO)、哈斯(HAAS)数控加工中心；大隈(OKUMA)数控车床，琼格(JUNG)数控成型磨床、克林伯格(KELLENBERGER-100)数控内外圆磨床、摩尔(MOORE)坐标磨床及蔡司(ZEISS)三次元等先进的制造设备及检测仪器，经过20年多年的技术沉淀及经验积累，已发展成具有一定规模的生产企业。

公司主要生产：零点快换夹具系列；电极制造夹具系列；自定心虎钳及燕尾槽夹具系列；夹头、导套等轴类产品系列，广泛应用于模具电极制造和零件加工领域，适用于加工中心、数控车床、电火花机、线切割等设备，凭借产品丰富、品质稳定、价格合理，赢得客户的信赖与支持，产品远销美国、俄罗斯、德国、瑞士、意大利、法国、西班牙、以色列、日本、韩国等国家。

并于2022年苏州生产基地正式竣工投产，使用面积达25000平方米，为高品质、批量化生产提供强有力保证，并承接非标夹具设计、精密零件及OEM委托制造服务，助您开创事业新版图。

精钻公司始终坚持：为企业及行业发展有所贡献而奋斗，我们以此为目标，专注行业发展，洞察客户需求，综合综效，以双赢思维服务好每一位客户。

Company profile

Since its establishment in 2000, Shenzhen Jingzuan Intelligent Manufacturing Co., Ltd. has been adhering to the business philosophy of "Keep Improving, Diamond Service", constantly introducing advanced equipment and technology, producing high-quality, stable and reliable products, and creating more value for customers. The company currently has MAKINO and HAAS CNC machining centers; OKUMA CNC lathes, JUNG CNC forming grinders, KELLENBERGER-100 CNC internal and external cylindrical grinders, MOORE coordinate grinder, ZEISS three-dimensional, other advanced manufacturing equipment and testing instruments. After more than 20 years of technical precipitation and experience accumulation, it has developed into a certain scale of production enterprises.

The company mainly produces: zero-point quick change fixture series; electrode manufacturing fixture series; self-centering vise and dovetail fixture series; shaft product series such as collet chuck and guide sleeves, which are widely used in the field of mold electrode manufacturing and parts processing, suitable for machining centers, CNC lathes, EDM machines, wire cutting and other equipment. With rich products, stable quality and reasonable prices, it has won the trust and support of customers. The products are exported to the United States, Russia, Germany, Switzerland, Italy, France, Spain, Israel, Japan, South Korea and other countries.

The Suzhou production base will be completed and put into operation in 2022, with an area of 25,000 square meters, providing a strong guarantee for high-quality, mass production, and undertaking non-standard fixture design, precision parts and OEM commissioned manufacturing services to help you create a new business map.

Jingzuan Company always insists: strive to contribute to the development of the enterprise and the industry. We take this as the goal, focus on industry development, insight into customer needs, integrate comprehensive results, and serve every customer with a win-win thinking.



苏州工厂



深圳工厂

- A-ONE快速定位夹具系统使用简单，将柔性和刚性完美结合。通过客户长期使用，一起见证A-ONE快速定位夹具在使用中体现：耐用、稳定、可靠。
- 标准化的接口—实现铣削、钻削、车削、磨削、电火花成型、线切割机床以及测量和预调台高效转换，确保加工品质，提高生产效率。

- A-ONE fast positioning fixture system is easy to use and makes perfect combination of flexibility and rigidity. Through the long-term use of customers, we will witness the A-ONE quick positioning fixture in use: durable, stable and reliable.
- Standardized interfaces – highly efficient conversion among the milling, drilling, turning, grinding, EDM shaping, linear cutting machine, measuring and presetting station, which can ensure machining quality and improve the production efficiency.



苏州生产车间

SUZHOU PRODUCTION WORKSHOP



制造设备 Manufacturing facilities

为满足客户大工件生产需求，精钻苏州工厂投资购置：大行程生产设备及检测仪器，如：大隈龙门加工中心，轴向行程：2000*1600*450、牧野数控卧式加工中心，轴向行程：1520*1250*1350，X、Y、Z轴光栅反馈0.1μm，冈本精密平面磨床及海克斯康三坐标测量仪

In order to meet the needs of customers for the production of large workpieces, JingZuan Suzhou factory invested and purchased: large-travel production equipment and testing instruments, such as: Okuma Machining Center, axial stroke: 2000*1600*450, Makino CNC horizontal machining center, axial stroke: 1520*1250*1350, X, Y, Z axis grating feedback 0.1um, Okamoto precision surface grinder and Hexagon three-coordinate testing equipment.

MAKINO 牧野卧式加工中心 a92 轴向行程：1520*1250*1350
X、Y、Z轴光栅反馈0.1μm



MAKINO 牧野卧式加工中心 a81NX 轴向行程：900*900*1020，X、Y、Z轴光栅反馈0.05μm

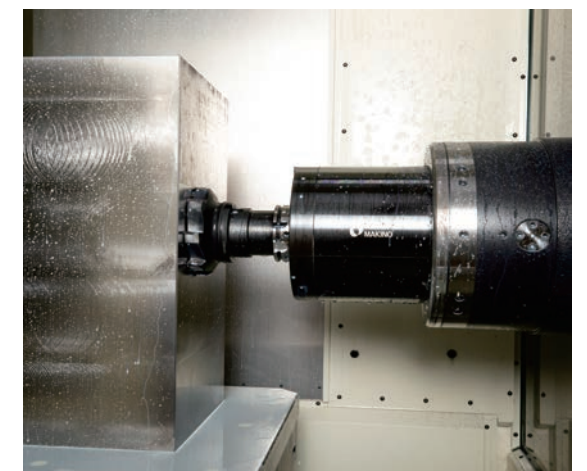

苏州生产车间

SUZHOU PRODUCTION WORKSHOP



OKUMA 大隈龙门加工中心 MCV-AII16*20 轴向行程: 2000*1600*450



OKAMOTO 冈本平面磨床 ACC105GX 工作台行程: 1150*540

苏州检测室

SUZHOU TESTING WORKSHOP



HEXAGON 海克斯康三坐标测量仪 SAGER 06.08.06
行程范围: 600*800*600, 长度测量误差: $E_0=0.6+L/400\mu\text{m}$, 重复精度: 0.5 μm



HEXAGON 海克斯康三坐标测量仪 Inspector Classic 12.22.10 行程范围: 1200*2200*1000

深圳生产车间

SHENZHEN PRODUCTION WORKSHOP



MAKINO加工中心 MAKINO Machining center



柔性生产线 Flexible production line

完整的、先进的生产加工设备、专职的技术人员及严格的生产工艺管控，保证了产品的交货期及配合客户应急的快速生产。

Complete, first-class processing equipment, professional technician and excellent manufacturing technique control, to ensure the product delivery and coordinate with emergency fasten manufacture as customer request.



OKUMA CNC 精加工 OKUMA CNC Precise machining



OKUMA 车床 OKUMA Lathe

深圳生产车间

SHENZHEN PRODUCTION WORKSHOP

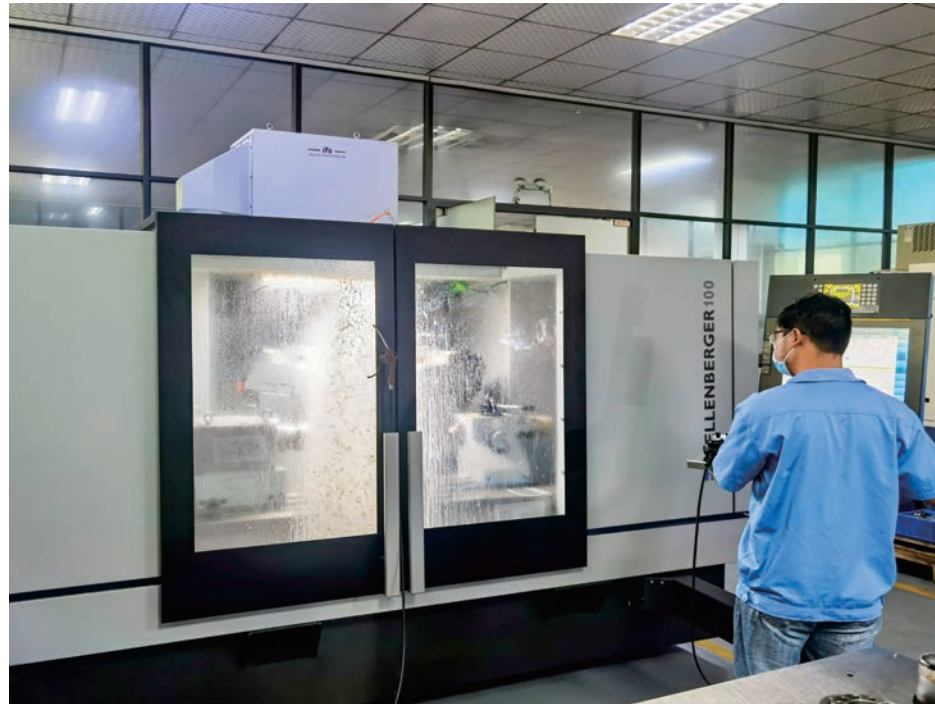

多达10种砂轮头架配置形式，所有砂轮头架均可进行直线或角向切入磨削，适用于外圆，内孔和端面磨削。控制系统的扩展软件，用于磨削标准非圆轮廓，例如：矩形，多边形，偏心圆，椭圆，半圆棒，扁平面等常见非圆轮廓。也用于磨削三棱形刀柄（COROMANT Capto），可进行圆周轮廓修正

Software extension on machine control. Simple program creation on machine control for grinding of standard non-circular contours such as Rectangle, Polygon, Eccentric, Ellipse, Rounded Bar, Flattening Subsequent Bar, Subsequent Square. Forms for polygon toolholders (COROMANT CAPTO) including extensive correction possibilities.

KELLENBERGER 100 — 完美的数控万能内外圆磨床
Perfect CNC universal inner and outer cylindrical grinding machine

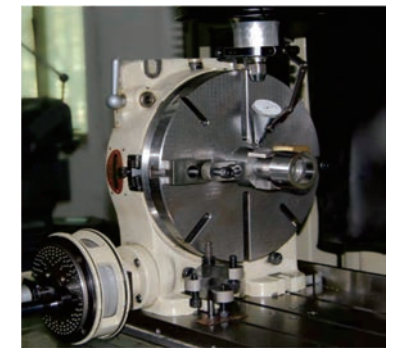



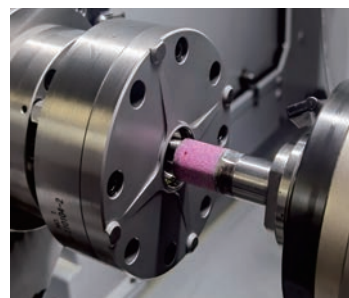









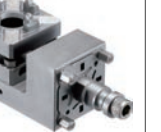

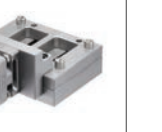











































MOORE 坐标磨车间 MOORE Coordinate grinding



斯图特内外圆磨 STUDER Internal and external grinding



JUNG 琼格磨床 JUNG Grinding machine

订货编号: 3A-100073  页码: 018	订货编号: 3A-200001  页码: 025	订货编号: 3A-200002  页码: 025	订货编号: 3A-200003  页码: 025	订货编号: 3A-200005  页码: 034	订货编号: 3A-200006  页码: 026	订货编号: 3A-200126  页码: 017	订货编号: 3A-200127  页码: 019	订货编号: 3A-200128  页码: 019	订货编号: 3A-200129  页码: 017	订货编号: 3A-200130  页码: 017	订货编号: 3A-200131  页码: 018
订货编号: 3A-200007  页码: 026	订货编号: 3A-200008  页码: 034	订货编号: 3A-200009  页码: 034	订货编号: 3A-200016  页码: 038	订货编号: 3A-200029  页码: 041	订货编号: 3A-200031  页码: 042	订货编号: 3A-200133  页码: 028	订货编号: 3A-200141  页码: 027	订货编号: 3A-210001  页码: 035	订货编号: 3A-210002  页码: 035	订货编号: 3A-210003  页码: 037	订货编号: 3A-210006  页码: 036
订货编号: 3A-200033  页码: 042	订货编号: 3A-200034  页码: 042	订货编号: 3A-200037  页码: 043	订货编号: 3A-200040  页码: 028	订货编号: 3A-200041  页码: 032	订货编号: 3A-200042  页码: 031	订货编号: 3A-210007  页码: 039	订货编号: 3A-210008  页码: 037	订货编号: 3A-210010  页码: 038	订货编号: 3A-210011  页码: 040	订货编号: 3A-210012  页码: 038	订货编号: 3A-210013  页码: 040
订货编号: 3A-200046  页码: 032	订货编号: 3A-200047  页码: 033	订货编号: 3A-200048  页码: 032	订货编号: 3A-200049  页码: 031	订货编号: 3A-200055  页码: 035	订货编号: 3A-200056  页码: 027	订货编号: 3A-210015  页码: 039	订货编号: 3A-210016  页码: 037	订货编号: 3A-210018  页码: 040	订货编号: 3A-210019  页码: 039	订货编号: 3A-210020  页码: 036	订货编号: 3A-210021  页码: 041
订货编号: 3A-200105  页码: 026	订货编号: 3A-200106  页码: 031	订货编号: 3A-200108-200115  页码: 030	订货编号: 3A-200109  页码: 020	订货编号: 3A-200124  页码: 018	订货编号: 3A-200125  页码: 019	订货编号: 3A-210023  页码: 029	订货编号: 3A-210024  页码: 029	订货编号: 3A-210025  页码: 029	订货编号: 3A-210026  页码: 030	订货编号: 3A-210027  页码: 044	订货编号: 3A-210028  页码: 044

订货编号: 3A-210029



页码: 044

订货编号: 3A-210039



页码: 043

订货编号: 3A-210040



页码: 043

订货编号: 3A-400006



页码: 020

订货编号: 3A-400008



页码: 020

订货编号: 3A-400092



页码: 020

线切割快速定位系统--R系列

A-ONE Wire EDM Tooling-R series



P.15~P.20



3A-200130



3A-200129



3A-200131



3A-400092



3A-200126



3A-400008



3A-400043



3A-200109



3A-200128



3A-200124



3A-200125



3A-100073

3A-200126 R型卧式自动基准座
R pneumatic chuck

- ▶ 应用 水平安装于工作台面, 适用3A-400092拉杆
- ▶ 参数 气动, 解锁气压0.6MPa
固定分度位置4X90°
Z基准面喷气清理
- ▶ 净重 1.2KG
- ▶ Application Mounted horizontally on worktable, suitable for drawbar 3A-400092
- ▶ Parameters Pneumatic, unlock air pressure 0.6MPa
Fixed index positions 4X90°
Air-blast cleaning of Z-references
- ▶ Net weight 1.2KG

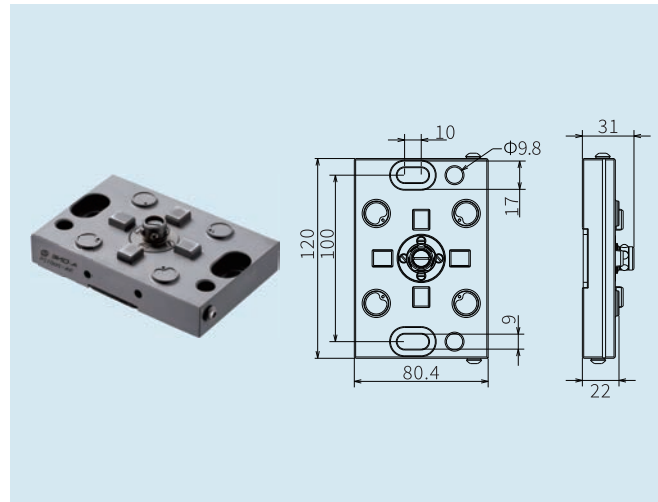

3A-200131 超级虎钳
Super vise

- ▶ 应用 水平夹紧矩形工件, 有专用连接接口, 适用于3A-200129三向找正座
- ▶ 特点 柔性钳口, 三个面同时产生夹紧力
- ▶ 夹持范围 0-100mm
- ▶ 最大负荷 7KG
- ▶ 最大扭矩 7Nm
- ▶ 净重 1.1KG
- ▶ Application For clamping rectangular workpieces horizontally with dedicated connecting interface, applicable in levelling adapter 3A-200129
- ▶ Feature Vise with flexible jaws, three sides simultaneously generate clamping force
- ▶ Clamping Range 0-100mm
- ▶ Load Max 7KG
- ▶ Max torque 7Nm
- ▶ Net weight 1.1KG

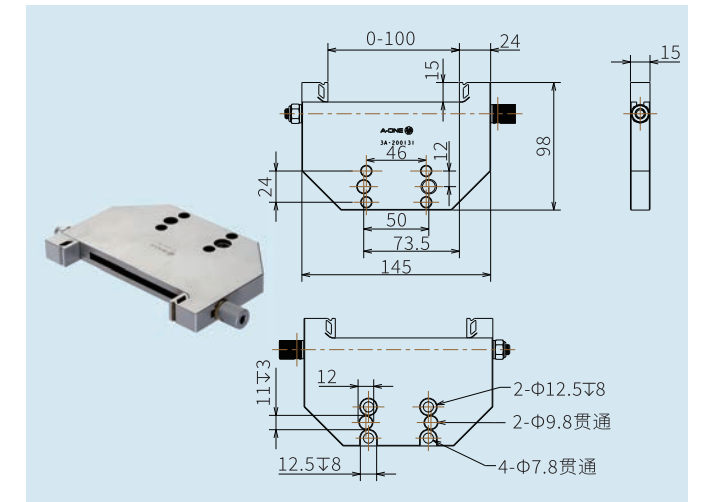

3A-200129 三向找正座
Levelling adapter

- ▶ 规格 可用于自动换装, 不配拉杆; 可安装识别芯片
- ▶ 应用 用于将虎钳或工件夹持器安装在R基准座上
- ▶ 载重 最大15KG
- ▶ 净重 2.4KG
- ▶ Version Adapted for automatic changing, supplied without drawbar, ready for code carrier
- ▶ Application For mounting vise, a holder or a fixture on R reference base
- ▶ Load Max 15KG
- ▶ Net Weight 2.4KG

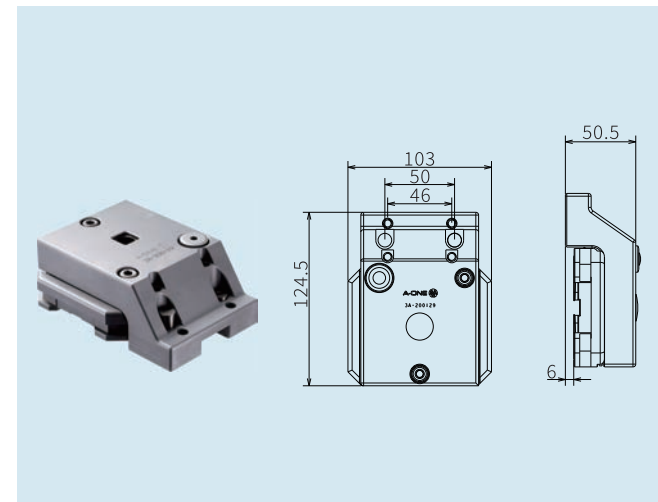

3A-100073 手动卡盘R50
Quick chuck R50

- ▶ 规格 R50手动
- ▶ 应用 适用定位片3A-400008; 适用拉杆3A-400006
- ▶ 安装 4-M8从背面或4-M6从正面
- ▶ 重复定位精度 0.002mm
- ▶ 夹紧力 4000N
- ▶ 净重 0.6KG
- ▶ Version R50, Manual
- ▶ Application Suitable for centering plate 3A-400008 and drawbar 3A-400006
- ▶ Mounting 4-M8 from bottom side or 4-M6 from front side
- ▶ Repeatability 0.002mm
- ▶ Clamping force 4000N
- ▶ Net weight 0.6KG

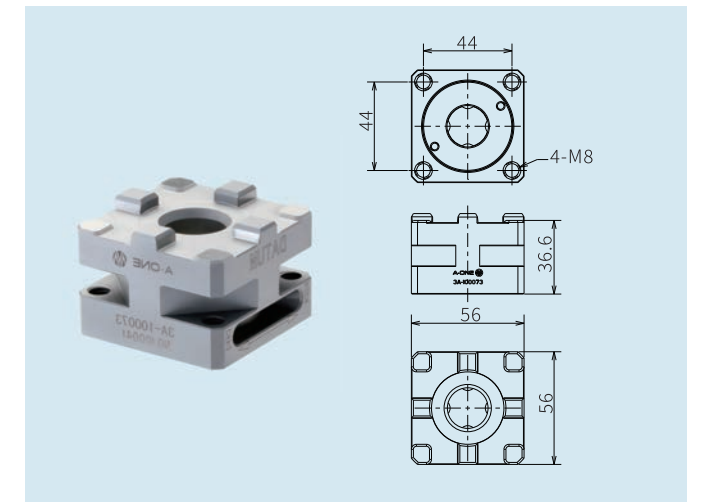

3A-200130 R强力虎钳
R super vise

- ▶ 应用 水平夹紧150mm以内的矩形工件
有专用连接接口, 适用于3A-200129三向找正座
- ▶ 最大负荷 12KG
- ▶ 紧固扭矩 10Nm(推荐)
- ▶ 净重 2.4KG
- ▶ Application For clamping rectangular workpieces up to 150mm horizontally, with dedicated connecting interface, applicable in levelling adapter 3A-200129
- ▶ Load Max 12KG
- ▶ Tightening torque 10Nm (recommend data)
- ▶ Net weight 2.4KG

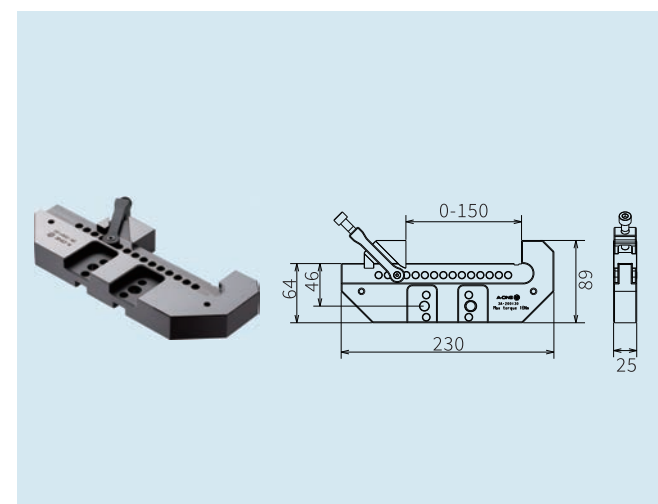

3A-200124 可调线割卡盘R50
Adjustable wire-cut EDM chuck R50

- ▶ 规格 含3A-100073 手动卡盘R50
- ▶ 应用 线切割机工作台
- ▶ 特点 安装平面精度可微调
- ▶ 净重 4.2KG
- ▶ Version With manual chuck R50 3A-100073
- ▶ Application Suitable for all types of wire-cut EDM machine worktable
- ▶ Characteristic The installation surface can be precisely adjusted
- ▶ Net weight 4.2KG

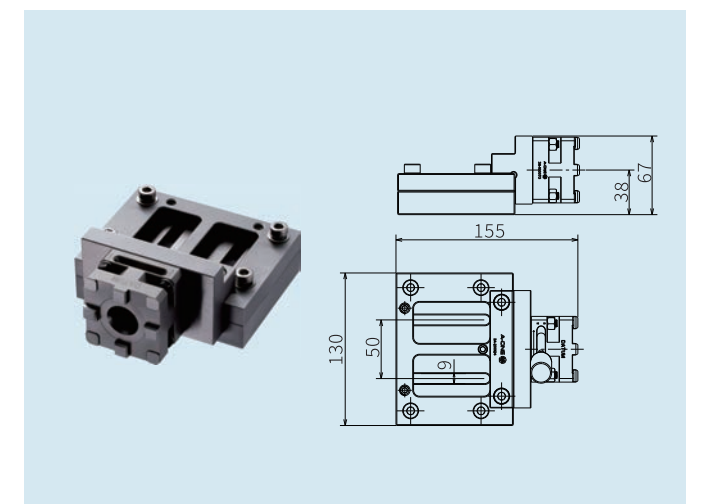

3A-200125 线割卡盘R50
Wire-cut EDM chuck R50

- ▶ 规格 含3A-100073手动卡盘R50
- ▶ 应用 机床工作台基面
- ▶ 安装 100mm间隔的M8连接孔
- ▶ 净重 2.1KG
- ▶ Version With manual chuck R50 3A-100073
- ▶ Application Suitable for the base of machine table
- ▶ Mounting M8 connection hole with 100mm interval
- ▶ Net weight 2.1KG

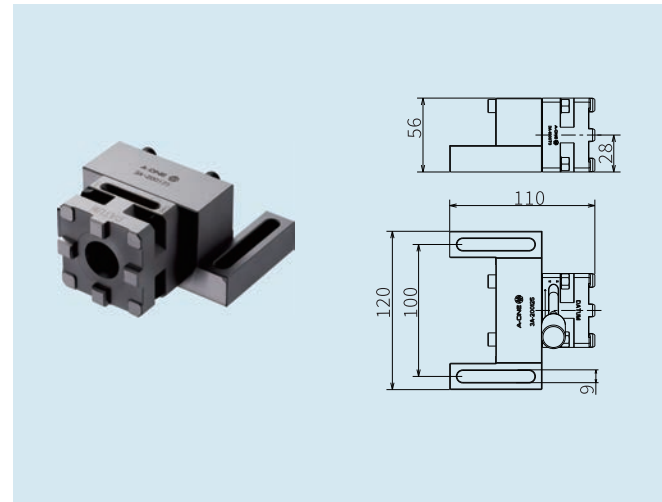

3A-200127 R型延伸臂
R Extension arm UnoSet

- ▶ 规格 可由垂直加工转为水平式加工
加工方便、快捷
含卡盘
- ▶ 应用 适用于各种线切割机, 电火花
- ▶ 净重 2.3KG
- ▶ Version Can be changed from vertical position to horizontal position
Easy and quick change
With chuck
- ▶ Application To be used on all types of wire-cut EDM or EDM
- ▶ Net weight 2.3KG

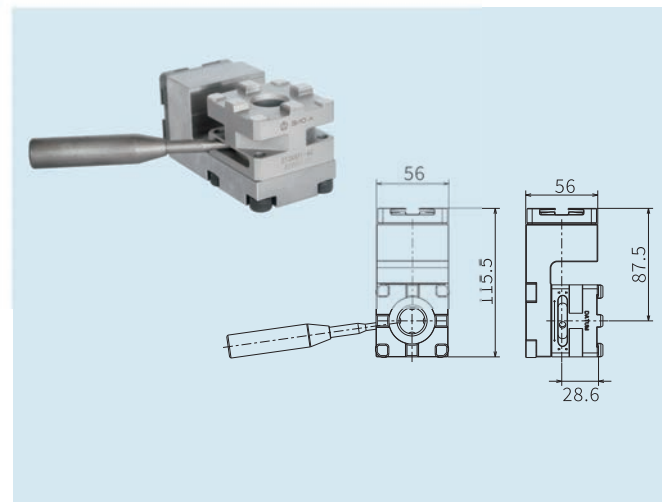

3A-200128 R型可调扁平虎钳
R type adjustable flat vise

- ▶ 规格 X, Y双向微调, 8mm扁平虎钳
- ▶ 应用 侧面夹持尺寸0-100mm的工件
- ▶ 夹持范围 0-100mm
- ▶ 最大负荷 5KG
- ▶ 净重 1.2KG
- ▶ Version Double action X, Y precise adjustment, 8mm flat vise
- ▶ Application Lateral clamping of workpieces machined outside of 0-100mm
- ▶ Clamping range 0-100mm
- ▶ Load Max 5KG
- ▶ Net weight 1.2KG

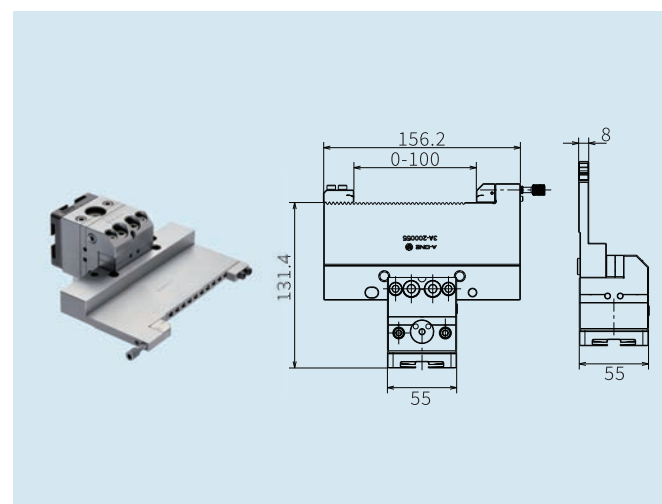

3A-200109 旋转摆动式虎钳0-100 UnoSet
Rotatable pendulum vise 0-100 UnoSet

- ▶ 规格 X, Y, Z 多向精度微调。适合小型工件夹持定位
- ▶ 应用 适用于各种品牌线切割机
- ▶ 备注 配有三副卡爪, 其装夹范围分别为0~50mm, 50~75mm, 75~100mm
- ▶ 净重 1.9KG
- ▶ Version X, Y, Z axis precision control. Suitable for small workpiece clamping position
- ▶ Application To be used on all kinds of wire-cut EDM
- ▶ Note With 3 pairs of jaws, the clamping range is 0-50mm, 50-75mm, 75-100mm
- ▶ Net weight 1.9KG

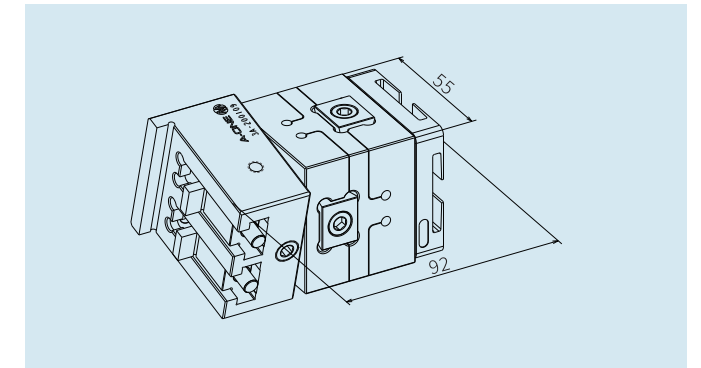

3A-400006 R型拉钉
R Type drawbar

- ▶ 规格 Ø20 x 36.9 mm, 带有Ø7mm冲洗孔
防锈
单独供应
- ▶ 应用 R型手动卡盘适用
- ▶ 净重 0.06KG
- ▶ Version Ø20*36.9 mm, with flushing holes Ø7 mm
Rust-resistant
Supplied singly
- ▶ Application Suitable for R manual chuck
- ▶ Net weight 0.06KG

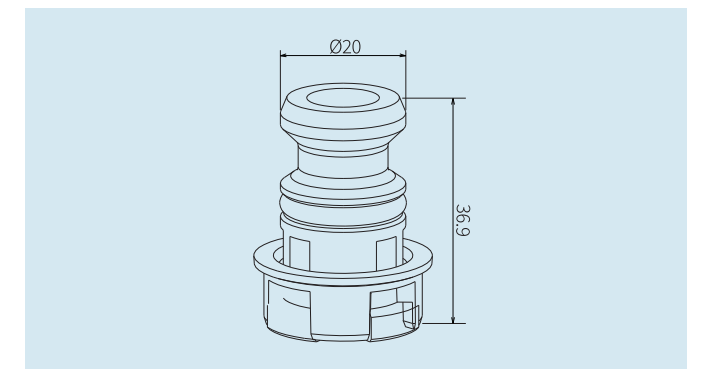

3A-400008 R型定位片
R Centering plate

- ▶ 规格 用于铜电极和工件的54*54mm 淬火基准元件
对于石墨电极, 需使用垫板
- ▶ 注意 必须先将其在铜制毛坯/工件上, 然后才能将其锁定在卡盘中
- ▶ 净重 0.15KG
- ▶ Version Reference Element 54X54mm
Must use plate if you clamp graphite
- ▶ Note Must be mounted on the copper blank/workpiece before it is locked in a chuck
- ▶ Net weight 0.15KG

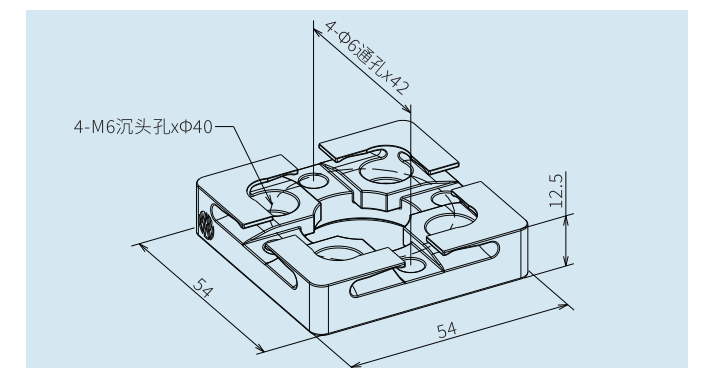

3A-400092 拉杆
Drawbar

- ▶ 规格 Ø20x13mm
耐锈
一套10个
- ▶ 净重 0.02KG
- ▶ Version Ø20*13mm
Rust-resistant
Set of 10 units
- ▶ Net weight 0.02KG

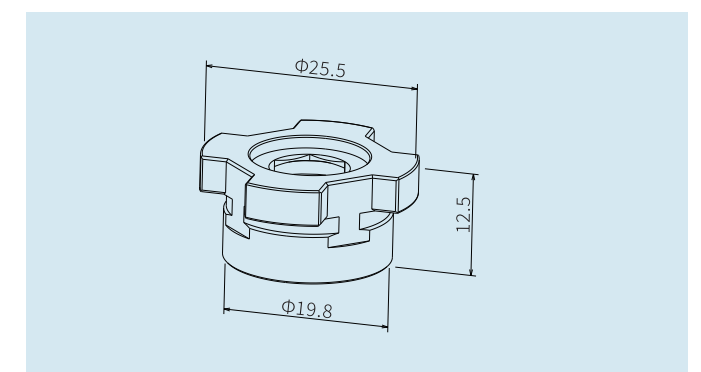

<http://www.szjztools.com>
<http://www.system3a.com>

最新产品信息, 公司资讯等敬请浏览本公司主页
Please visit our homepage for the latest product information, company information, etc.

A-ONE 线切割夹具 A-ONE Wire EDM Tooling



P.23~P.44



3A-200001



3A-200002



3A-200004



3A-200007



3A-200056



3A-200006



3A-200105



3A-200040



3A-200042



3A-200049



3A-200106



3A-200041



3A-200048



3A-200046

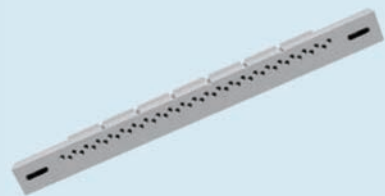

3A-200108



3A-200005



3A-200008



3A-200055



3A-210019



3A-210016



3A-200047



3A-200029



3A-200033



3A-200034

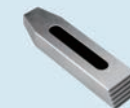

3A-200031



3A-200037



3A-210027



3A-210028

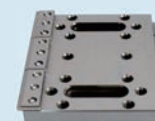

3A-210029

3A-200001 50型手动卡盘
Quick chuck 50

- ▶ 规格 系统尺寸ITS 50, 手动, 防腐蚀
- ▶ 连接 4个M8螺钉从背面或4个M6带螺母的柱头螺钉
- ▶ 应用 在电火花机/线切割机床上装夹精铣和磨过的工件
- ▶ 注意 夹紧力高达4000N
- ▶ 净重 0.8KG
- ▶ Version System size ITS 50, manual, corrosion resistant
- ▶ Connection 4×M8 from the rear or 4×M6 stud bolts with nuts
- ▶ Application On EDM/WEDM centers for precision milling and grinding workpiece
- ▶ Note Clamping force up to 4000N
- ▶ Net weight 0.8KG

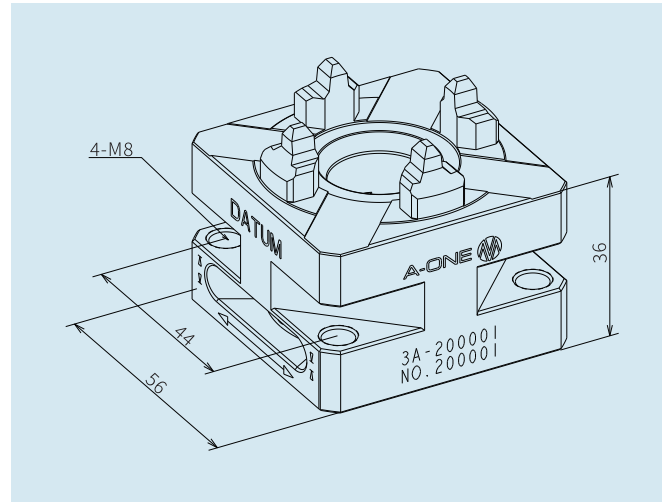

3A-200006 可调式线割夹具
Wire-cut vise

- ▶ 规格 可在X, Y, Z多向精度微调, 手动锁紧功能, 含卡盘
- ▶ 应用 适用于各种品牌线割机, 直接安装在工作台上
- ▶ 净重 3.6KG
- ▶ Version Precise adjustment to X, Y, Z axis, Power manual lock, With chuck
- ▶ Application Suitable for all types of wire-cut EDM, to be mounted directly on machine table
- ▶ Net weight 3.6KG

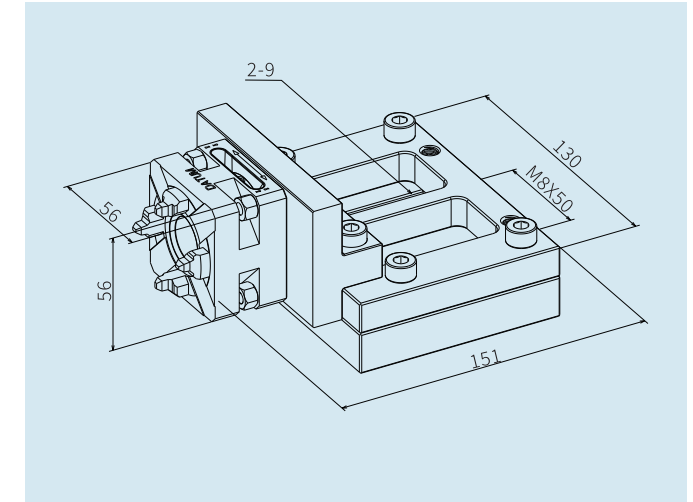

3A-200002 旋转摆动式虎钳 0 - 100 UnoSet
Rotatable pendulum vise 0 - 100 UnoSet

- ▶ 规格 X, Y, Z 多向精度微调, 适合小型工件夹持定位
- ▶ 应用 适用于各种品牌线割机
- ▶ 注意 配有三副卡爪, 其装夹范围分别为0~50mm, 50~75mm, 75~100mm
- ▶ 净重 1.9KG
- ▶ Version X, Y, Z axis precision control. Suitable for small workpiece clamping position
- ▶ Application To be used on all kinds of wire-cut EDM
- ▶ Note Contain 3 pairs of jaws, the clamping range is 0-50mm, 50-75mm, 75-100mm
- ▶ Net weight 1.9KG

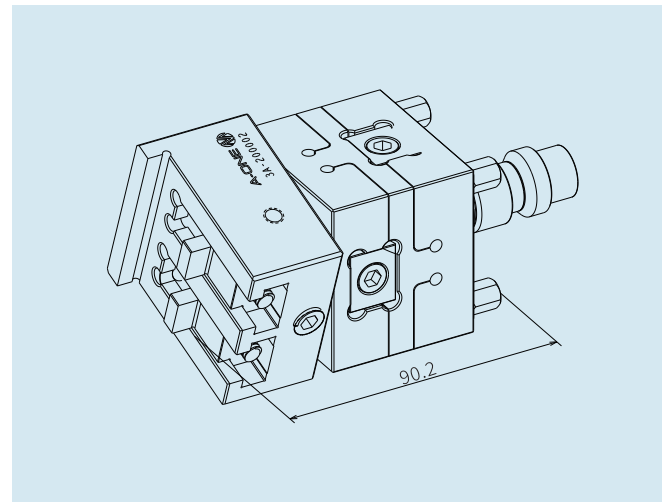

3A-200105 快速卡盘 50 RSM/UnoSet 连过渡板 R=100mm
Clamping chuck 50 RSA/UnoSet on adapter plate R=100mm

- ▶ 规格 固定于过渡板上的卡盘 50, 手动
- ▶ 应用 用100mm 间隔的连接孔直接安装于任何机床的基面
- ▶ 净重 2.1KG
- ▶ Version Chuck 50 on adapter plate, manual
- ▶ Application To be fitted directly to any machine bases with attachment boreholes in a 100 mm grid
- ▶ Net weight 2.1KG

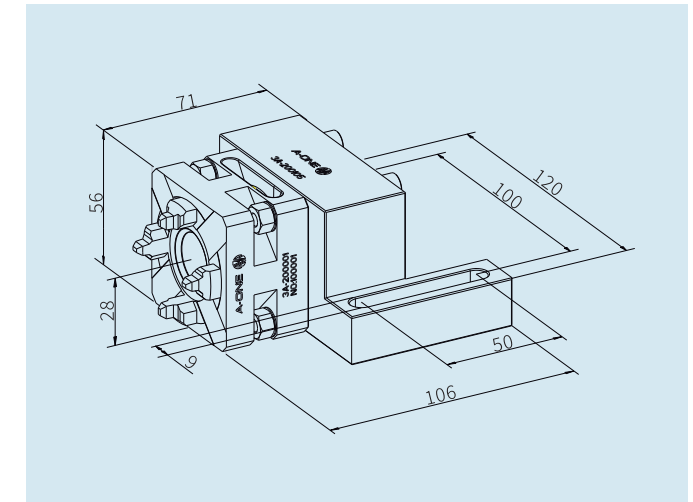

3A-200003 延伸臂 UnoSet
Extension arm UnoSet

- ▶ 规格 可由垂直加工转为水平式加工, 加工方便、快捷, 含卡盘
- ▶ 应用 适用于各种线割机, 电火花. 可配合各式卡盘使用.
- ▶ 净重 1KG
- ▶ Version Can be changed from vertical position to horizontal position, Easy and quick change, With chuck
- ▶ Application To be used on all types of wire-cut EDM or EDM, Can be used with all kinds of chucks.
- ▶ Net weight 1KG

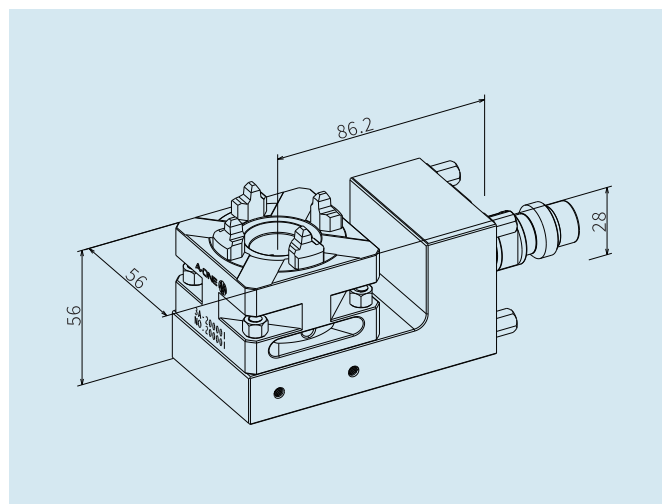

3A-200007 V型夹头 UnoSet
V-block holder UnoSet

- ▶ 规格 可实现圆柱体工件的快速夹持、定位, 加工方便、快捷
- ▶ 应用 适用于各种品牌线割机, 需配合3A-200006或3A-200105底座使用
- ▶ 净重 1.2KG
- ▶ Version Quick clamp and position of round shape workpiece, Processing easy and quickly
- ▶ Application To be used on all types of wire-cut EDM, Need to be used With 3A-200006 or 3A-200105 base
- ▶ Net weight 1.2KG

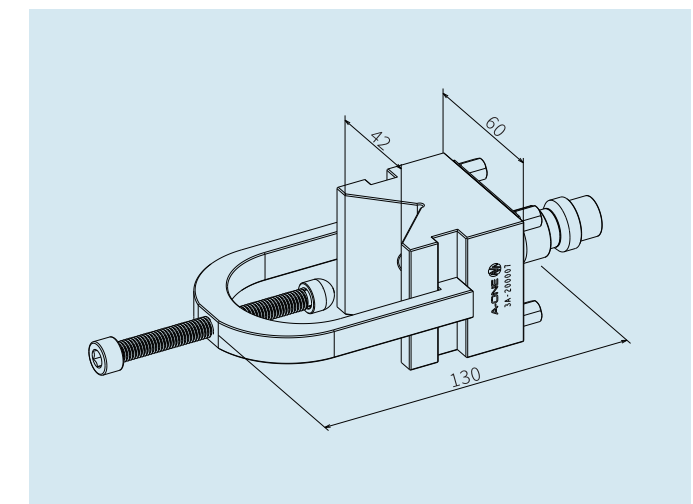

3A-200056 扁平虎钳8mm UnoSet
Flat vise 8mm UnoSet

- ▶ 规格 一个可移动夹爪和一个固定式夹爪。硬质，磨削，耐腐蚀
- ▶ 夹持 0-100 mm
- ▶ 最大负载 5KG
- ▶ 应用 侧面夹持尺寸0-100 mm的工件
需配合3A-200006或3A-200105底座使用
- ▶ 净重 2.4KG
- ▶ Version One movable jaw and one fixed jaw. Hardened, ground and corrosion-resistant
- ▶ Clamping range 0-100 mm
- ▶ Load Max 5KG
- ▶ Application Lateral clamping of workpieces machined outside of 0-100mm, to be used with 3A-200006 or 3A-200105
- ▶ Net weight 2.4KG

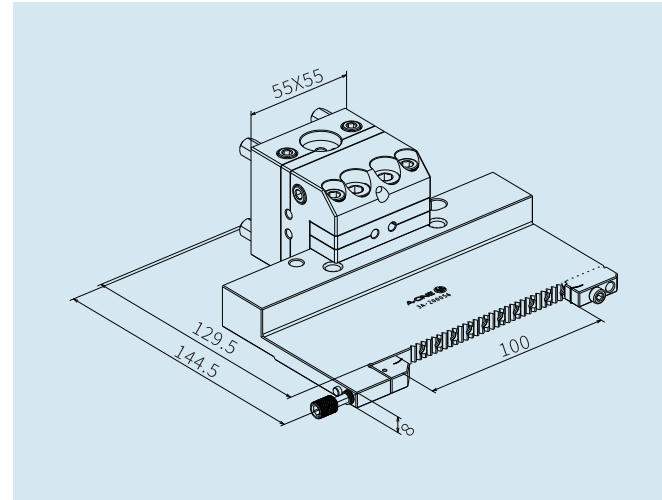

3A-200141 三向微调虎钳
3 axis precise adjustable vise

- ▶ 规格 防腐材质，ITS50标准接口，可实现三向精度调节，夹持范围0-52mm
- ▶ 应用 适用于线切割机
- ▶ Version Anti-corrosion material, ITS50 standard interface, can realize 3 axis precision adjustment, clamping range 0-52mm
- ▶ Application Suitable for wire EDM

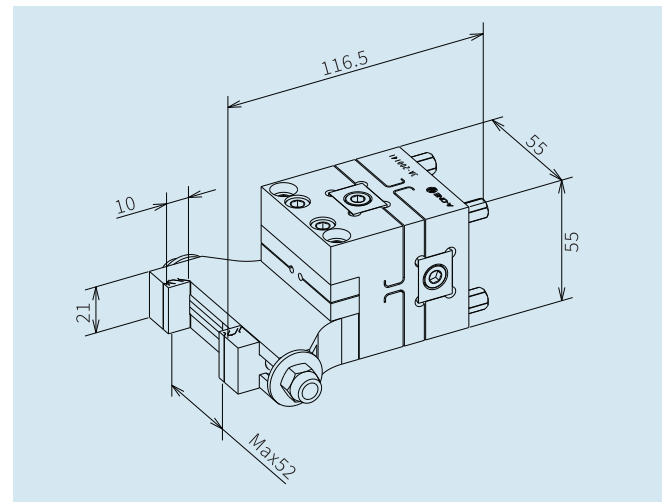

3A-200142 三向微调虎钳R
3 axis precise adjustable vise

- ▶ 规格 防腐材质，ITS50标准接口，可实现三向精度调节，夹持范围0-52mm
- ▶ 应用 适用于线切割机
- ▶ Version Anti-corrosion material, ITS50 standard interface, can realize 3 axis precision adjustment, clamping range 0-52mm
- ▶ Application Suitable for wire EDM

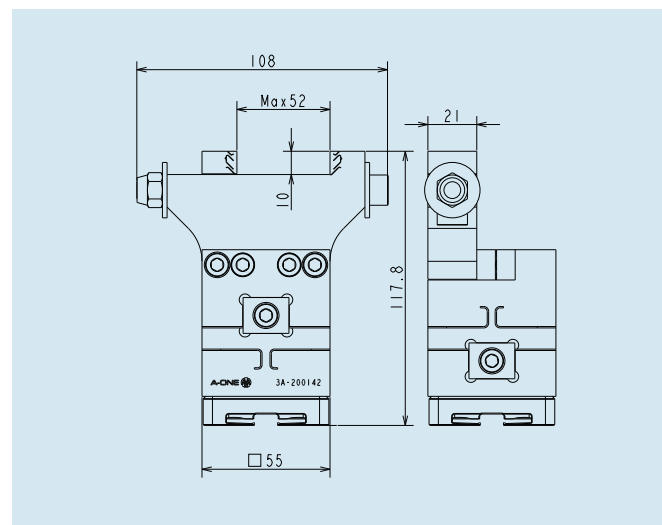

3A-200040 基准杆
Reference pin UnoSet

- ▶ 规格 硬质，磨削，孔Φ8mm基准孔
- ▶ 应用 水平卡盘上确定测量基准
- ▶ 净重 1.4KG
- ▶ Version Hardened, ground, borehole Φ8 mm
- ▶ Application To determine reference measurements on horizontal chucks
- ▶ Net weight 1.4KG

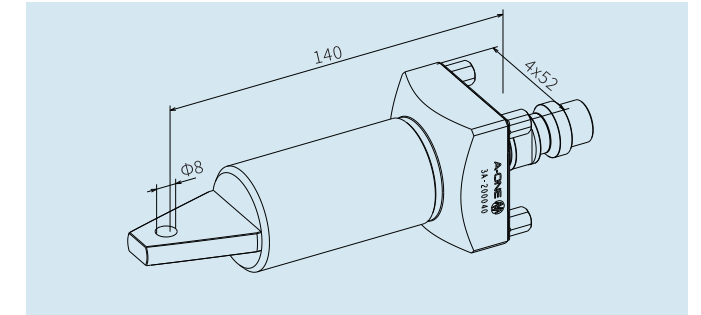

3A-200133 可调横梁
Adjustable beam

- ▶ 特点 材质采用高级不锈钢，真空热处理后经深冷处理至硬度HRC50~55再进行研磨加工，因此本体不易变形。
- ▶ 应用 用于线切割机大尺寸的零件加工，产品可根据客户机床行程定做
- ▶ 平行精度 0.002/100mm以内
- ▶ 垂直精度 0.002/100mm以内
- ▶ 注意 工件最大重量：70kg(两根一起使用时候)，超过70kg时，螺丝等任何部件都可能损伤
- ▶ Characteristics The material is stainless steel, have done vacuum harden treatment and deeply cold treatment to HRC50~55 before doing the grinding process, the essence is not easy to deformed.
- ▶ Application The crossbeam is suitable for machining large-size parts of wire cutting machine tools, and the products can be customized according to the travel of the machine tools of customers.
- ▶ Parallelism Within 0.003/100mm
- ▶ Squareness Within 0.005/100mm
- ▶ Note Maximum weight of workpiece: 70kg (when two pieces are used together), any part such as screw may be damaged when the weight exceeds 70kg.

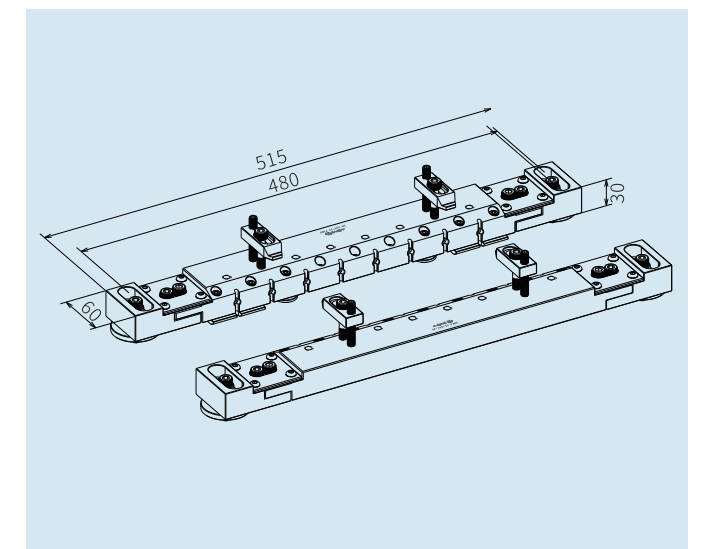

工作原理
working principle:

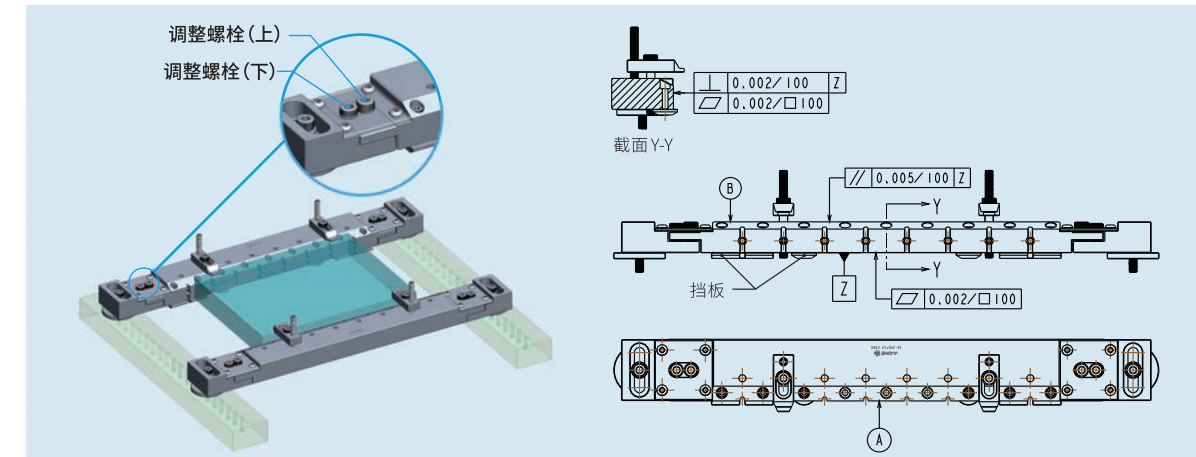

- 首先，请根据被加工物的大小改变横梁底部挡板的位置。
1. First, please change the position of the baffle at the bottom of the beam according to the size of the processed object.
 - 校正横梁主体基准面(A)，使用千分表进行打表校正使其与机台的X/Y轴平行。
2. Calibrate the reference plane (a) of the main body of the crossbeam, and use a dial indicator to make it parallel to the X/Y axis of the machine.
 - 水平方向的校正：
(1) 在被加工物基准面(上表面)使用千分表进行打表校正，调整螺栓(上)顺时针方向转动，B部上升。
(2) 调整螺栓(下)顺时针方向转动，B部分下降。交替使用上下用的调整螺栓，使其水平。
3. Correction of horizontal direction:
(1) use a dial indicator to mark and calibrate the reference surface (upper surface) of the object to be processed, adjust the bolt (upper) to rotate clockwise, and raise Part B.
(2) adjust the bolt (lower) to rotate clockwise and lower part B. Use the upper and lower adjusting bolts alternately to make them horizontal.
- 注意：横梁校正完成后，请确认所有的调节螺栓都要拧紧。
Note: after the beam calibration, please confirm that all the adjusting bolts should be tightened.

3A-210023 横梁
Wire cut bridge

- ▶ **特点** 材质采用高级不锈钢,真空热处理后经深冷处理至硬度HRC50~55再进行研磨加工,因此本体不易变形。
- ▶ **应用** 较适合面积大及重量较重的工件使用。
- ▶ **平行精度** 0.003/100mm以内
- ▶ **垂直精度** 0.005/100mm以内
- ▶ **Characteristics** The material is stainless steel, have done vacuum harden treatment and deeply cold treatment to HRC50~55 before doing the grinding process, the essence is not easy to deformed.
- ▶ **Application** Suitable for workpieces with large area and heavy weight.
- ▶ **Parallelism** Within 0.003/100mm
- ▶ **Squareness** Within 0.005/100mm

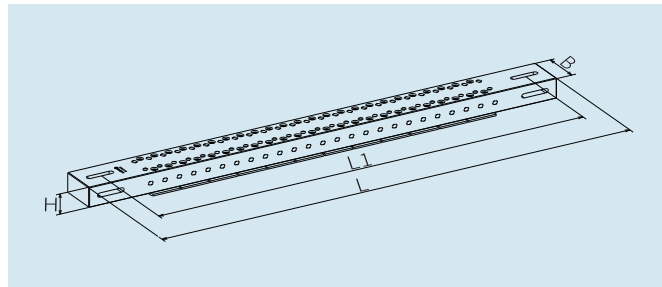

尺寸Size(mm) 型号 Model	L	L1	B	H	最大负载 Max. Load(Kg)	重量(kg) Weight
**	370	-	50	25	-	4
**	450	-	50	30	-	9
**	550	-	50	30	-	10.5
**	650	-	60	35	-	-
**	750	-	60	40	-	-
**	950	-	80	45	-	-

3A-210026 夹紧梁
Wire cut bridge

- ▶ **特点** 材质采用高级不锈钢,真空热处理后经深冷处理至硬度HRC50~55再进行研磨加工,因此本体不易变形。
- ▶ **应用** 较适合面积大及重量较重的工件使用。
- ▶ **平行精度** 0.003/100mm以内
- ▶ **垂直精度** 0.005/100mm以内
- ▶ **Characteristics** The material is stainless steel, have done vacuum harden treatment and deeply cold treatment to HRC50~55 before doing the grinding process, the essence is not easy to deformed.
- ▶ **Application** Suitable for workpieces with large area and heavy weight.
- ▶ **Parallelism** Within 0.003/100mm
- ▶ **Squareness** Within 0.005/100mm

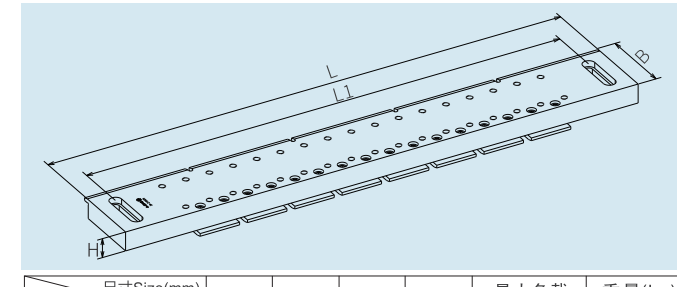

尺寸Size(mm) 型号 Model	L	L1	B	H	最大负载 Max. Load(Kg)	重量(kg) Weight
**	370	-	90	22	-	-
**	450	-	90	22	-	-
**	550	-	90	25	-	-
**	650	-	90	25	-	-
**	750	-	90	25	-	-
**	950	-	90	30	-	-

3A-210024 夹紧梁
Wire cut bridge

- ▶ **特点** 材质采用高级不锈钢,真空热处理后经深冷处理至硬度HRC50~55再进行研磨加工,因此本体不易变形。
- ▶ **应用** 较适合面积大及重量较重的工件使用。
- ▶ **平行精度** 0.003/100mm以内
- ▶ **垂直精度** 0.005/100mm以内
- ▶ **Characteristics** The material is stainless steel, have done vacuum harden treatment and deeply cold treatment to HRC50~55 before doing the grinding process, the essence is not easy to deformed.
- ▶ **Application** Suitable for workpieces with large area and heavy weight.
- ▶ **Parallelism** Within 0.003/100mm
- ▶ **Squareness** Within 0.005/100mm

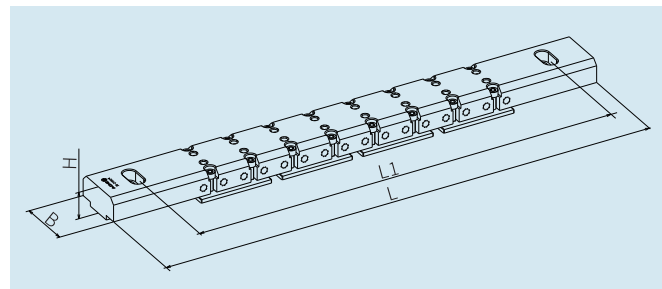

尺寸Size(mm) 型号 Model	L	L1	B	H	最大负载 Max. Load(Kg)	重量(kg) Weight
**	370	-	45	30	-	-
**	450	-	60	30	-	-
**	550	-	60	30	-	-
**	650	-	80	36	-	-
**	750	-	80	36	-	-
**	950	-	80	40	-	-

3A-200108 WEDM横梁SODICK机床适用
Sodick WEDM clamping beam

3A-200110 WEDM横梁SODICK机床适用
Sodick WEDM clamping beam

3A-200112 WEDM横梁SODICK机床适用
Sodick WEDM clamping beam

3A-200113 WEDM横梁SODICK机床适用
Sodick WEDM clamping beam

3A-200114 WEDM横梁SODICK机床适用
Sodick WEDM clamping beam

3A-200115 WEDM横梁SODICK机床适用
Sodick WEDM clamping beam

- ▶ **特点** 材质采用高级不锈钢,真空热处理后经深冷处理至硬度HRC50~55再进行研磨加工,因此本体不易变形。
- ▶ **应用** 适用于各类SODICK线切割机床,配合各类夹紧夹具工件。
- ▶ **平行精度** 0.003/100mm以内
- ▶ **垂直精度** 0.005/100mm以内
- ▶ **Characteristics** The material is stainless steel, have done vacuum harden treatment and deeply cold treatment to HRC50~55 before doing the grinding process, the essence is not easy to deformed.
- ▶ **Application** Suited for various Sodick WEDM machine, matching various of clamping tool to use
- ▶ **Parallelism** Within 0.003/100mm
- ▶ **Squareness** Within 0.005/100mm

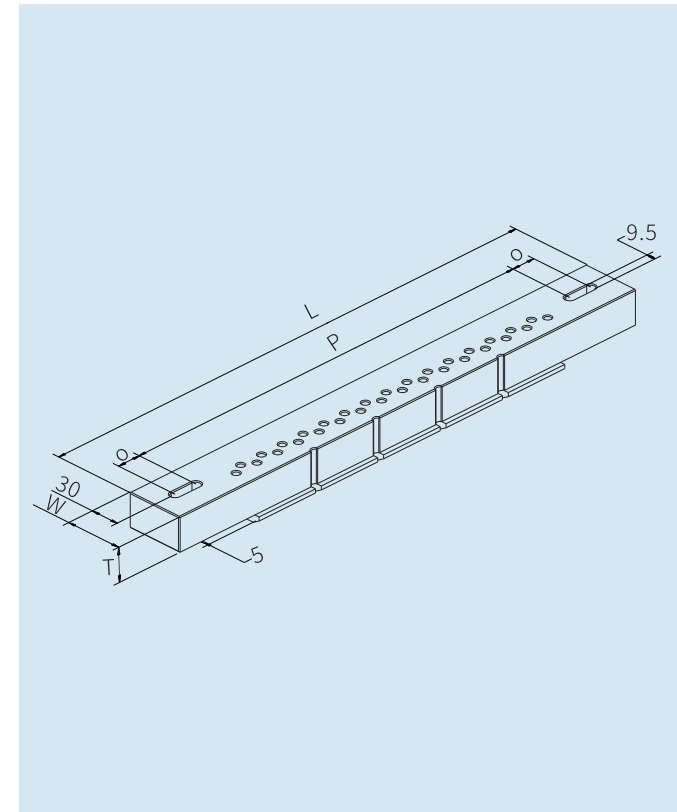

3A-210025 夹紧梁
Wire cut bridge

- ▶ **特点** 材质采用高级不锈钢,真空热处理后经深冷处理至硬度HRC50~55再进行研磨加工,因此本体不易变形。
- ▶ **应用** 较适合面积大及重量较重的工件使用。
- ▶ **平行精度** 0.003/100mm以内
- ▶ **垂直精度** 0.005/100mm以内
- ▶ **Characteristics** The material is stainless steel, have done vacuum harden treatment and deeply cold treatment to HRC50~55 before doing the grinding process, the essence is not easy to deformed.
- ▶ **Application** Suitable for workpieces with large area and heavy weight.
- ▶ **Parallelism** Within 0.003/100mm
- ▶ **Squareness** Within 0.005/100mm

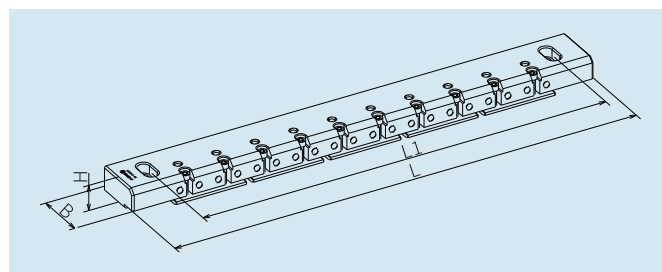

尺寸Size(mm) 型号 Model	L	L1	B	H	最大负载 Max. Load(Kg)	重量(kg) Weight
**	370	-	45	30	-	-
**	450	-	60	30	-	-
**	550	-	60	30	-	-
**	650	-	80	36	-	-
**	750	-	80	36	-	-
**	950	-	80	40	-	-

编号 Model No.	L*W*T*P*O	适用机床型号 (Applicable machine model)
3A-200108	550*60*35*450*25	AG40L/AQ325L/AQ327L/AQ360L/A325/A350(W)/EPOC300
3A-200110	750*60*35*630*35	G600L/AQ535L/AQ537L/AQ550L/AQ560L/AQ600/AQ600(W)
3A-200112	1100*70*1000*50	AQ900L
3A-200113	500*60*35*400*25	AD325/AQ300L/A300W/A320D/AP300/AP330/AW330/BF275/BF280L
3A-200114	650*60*35*550*25	AP450/AP500L/A5009(W)/A530D/AP450
3A-200115	950*70*50*850*25	AQ750L/A750(W)

3A-200042 横梁托板
Beam pallet PalletSet W

- ▶ 规格 托板, 适用于各类夹持元件。包括Z支撑和压板
- ▶ 应用 适用于固定式夹头或3D摆动式夹头
- ▶ 选项 棱形夹头和横梁虎钳夹持元件
- ▶ 净重 2.3KG
- ▶ Version Pallet to accommodate various clamping elements, Includes Z-supports and clips
- ▶ Application To be fitted to fixed holders or pendulum holders 3D
- ▶ Options Prism holders and BeamVise clamping elements
- ▶ Net weight 2.3KG

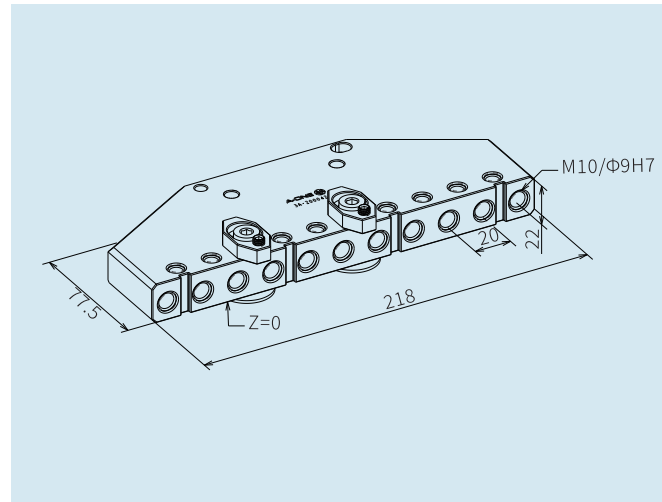

3A-200041 虎钳40mm
Vise PalletSet W 40mm

- ▶ 规格 虎钳, 带从上部连接的固定Z支撑和夹爪。硬质, 磨削。
- ▶ 夹持 最大150×150×40mm
- ▶ 最大负载 12KG
- ▶ 应用 侧面夹持尺寸0-150mm的工件。适用于固定式夹头或摆动式夹头
- ▶ 净重 1.8KG
- ▶ Version Vise with fixed Z-lip and jaws attached from above Hardened and ground
- ▶ Clamping range Max. 150 x 150 x 40 mm
- ▶ Load Max 12KG
- ▶ Application Lateral clamping of workpieces of 0 -150 mm machined from the outside. To be fitted to fixed holders or pendulum holders
- ▶ Net weight 1.8KG

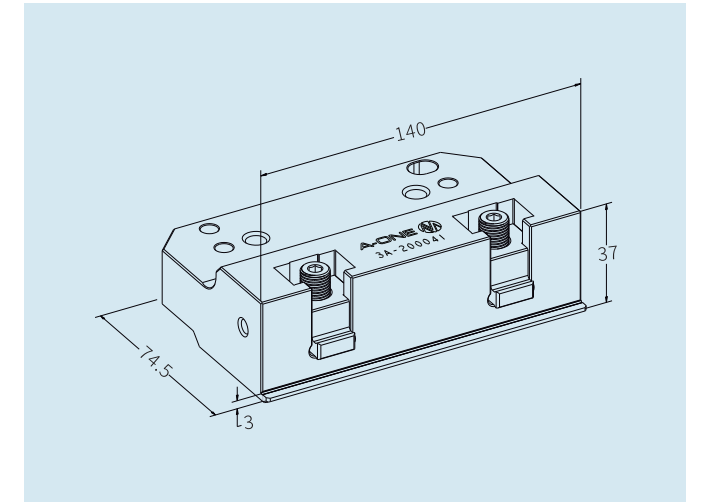

3A-200049 3D摆动式夹头
Pendulum holder 3D PalletSet W

- ▶ 规格 用于自动和手动装载的摆动头。使用G定位片, 以增加耐用性
- ▶ 应用 是万能虎钳方形块、框架托板、虎钳和横梁托板等所有其它夹持元件的基础
- ▶ 注意 X, Y, Z轴可调
- ▶ 净重 3.7KG
- ▶ Version Pendulum head for automatic and manual loading. G-Centering plate for increased durability
- ▶ Application Basis for all other clamping elements such as Universal vise square, frame pallet, vise and beam pallet
- ▶ Note Adjustable in the X-, Y- and Z-axes
- ▶ Net weight 3.7KG

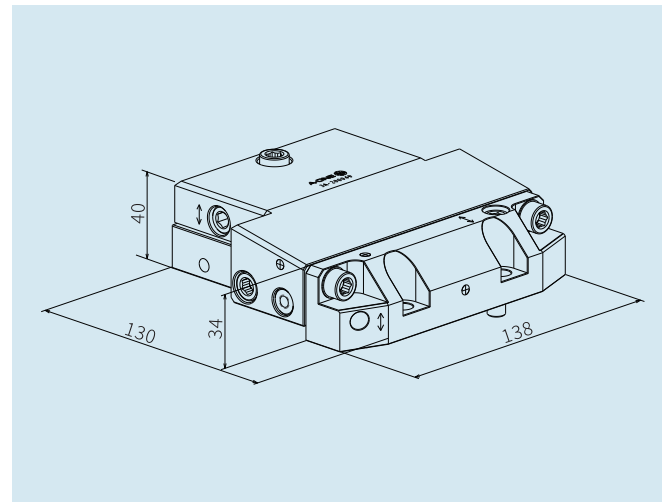

3A-200046 棱形夹头120mm
Prism holder 120mm PalletSet W

- ▶ 规格 带可分离Z支撑的棱形夹持元件
- ▶ 应用 夹持最大尺寸至Φ120mm圆柱形工件
- ▶ 安装 直接安装于固定式夹头或摆动式夹头
- ▶ 最大负载 10KG
- ▶ 净重 2.7KG
- ▶ Version Prism and clamping bars with detachable Z-supports
- ▶ Application To clamp cylindrical workpieces of up to ø 120 mm
- ▶ Mounting Directly to fixed holder or pendulum holder
- ▶ Load Max10KG
- ▶ Net weight 2.7KG

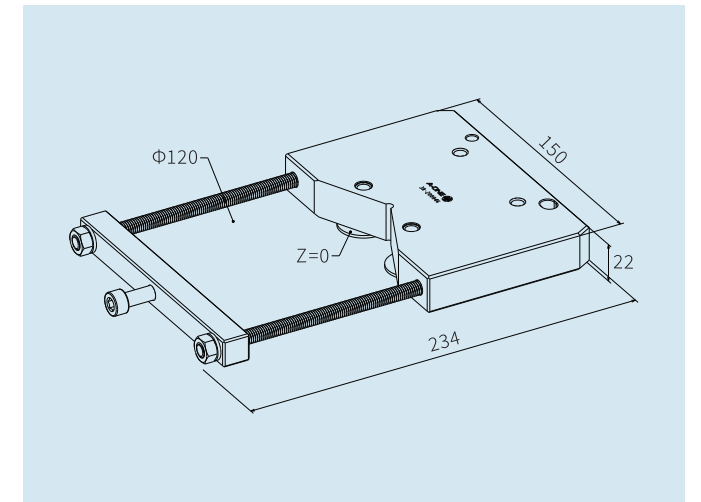

3A-200106 虎钳 PalletSet W
Vise PalletSet W

- ▶ 规格 带压板的夹持元件, 一面与工件相连
- ▶ 应用 适用于固定式夹头或摆动式夹头
- ▶ 最大负载 12KG
- ▶ 净重 1.4KG
- ▶ Version Clamping element with clips for one-sided attachment to workpieces
- ▶ Application To be fitted to fixed holders or pendulum holders
- ▶ Load Max 12KG
- ▶ Net weight 1.4KG

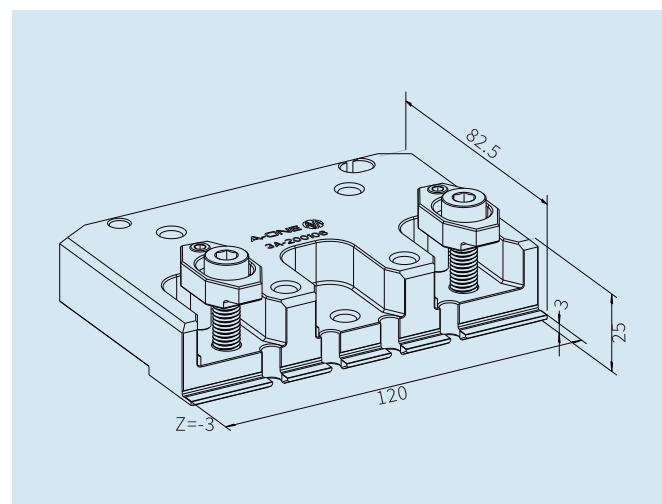

3A-200048 棱形夹头80
Prism holder 80 PalletSet W

- ▶ 规格 带可分离Z支撑的棱形夹持元件
- ▶ 应用 夹持最大尺寸至Φ80mm圆柱形工件
- ▶ 安装 安装于横梁托板或3A-200042夹紧梁的前部
- ▶ 最大负载 6KG
- ▶ 净重 0.9KG
- ▶ Version Prism and clamping part with detachable Z-supports
- ▶ Application Clamping of cylindrical workpieces of up to Ø 80 mm
- ▶ Mounting To be fitted to the front of beam pallet 3A-200042 clamping beams
- ▶ Load Max6 KG
- ▶ Net weight 0.9KG

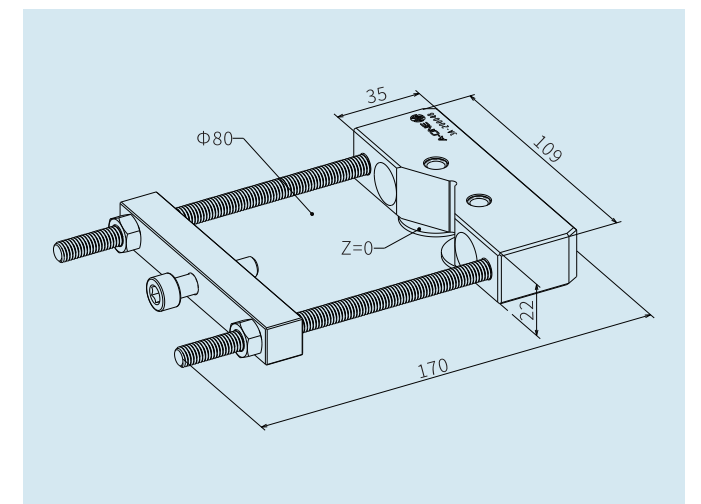

3A-200047 万能虎钳方形块
UniVise square PalletSet W

- ▶ 规格 方形块, 带所有的夹持附件
- ▶ 应用 适用于固定式夹头或摆动式夹头
- ▶ 最大负载 10KG
- ▶ 净重 1.8KG
- ▶ Version Square with all clamping accessories
- ▶ Application To be fitted to fixed holders or pendulum holders
- ▶ Load Max10 KG
- ▶ Net weight 1.8KG

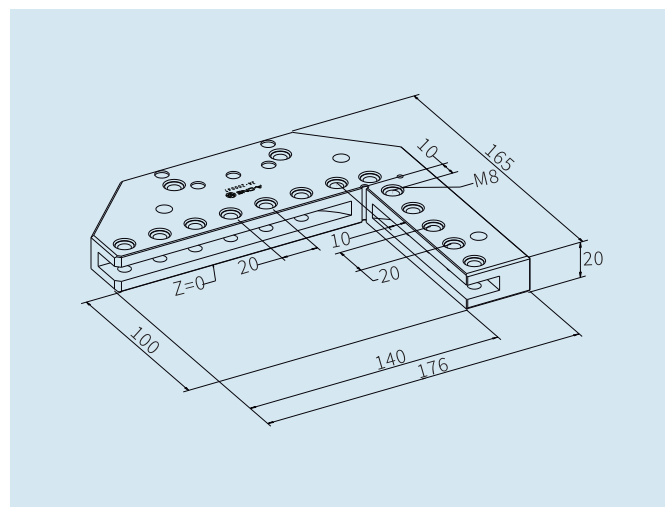

3A-200047 万能虎钳方形块
UniVise square PalletSet W

- ▶ 规格 为线切割机所配的基础工具系统
- ▶ 应用 适合小型和中型尺寸的工件的托板化
- ▶ 安装 视机床基面而定
- ▶ 套装包括 1个万能虎钳和配件
- ▶ Version Basic tooling system for wire cutting machine
- ▶ Application Suitable for palletizing small and medium size workpieces
- ▶ Mounting Depending on the machine base
- ▶ Kit contains 1 piece of UniVise and accessories

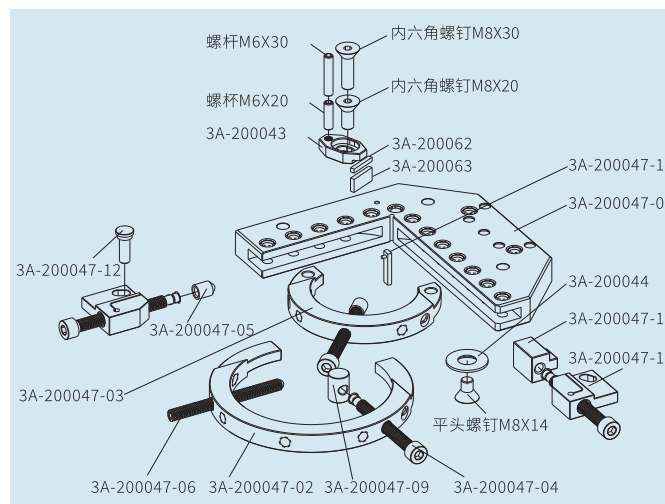

3A-200005 可调式线割批士
Adjustable vise

- ▶ 特点 材质采用高级不锈钢, 真空热处理后经深冷处理至硬度HRC50~55再进行研磨加工, 因此本体不易变形。
- ▶ 平行精度 0.003/100mm以内
- ▶ 垂直精度 0.005/100mm以内
- ▶ 夹持范围 最大开口155mm, 开口深度49.85mm
- ▶ 附件 含T型六角匙1PCS
- ▶ 净重 4.7KG
- ▶ 注意 产品红色标识禁止拆装
- ▶ Characteristics The material is stainless steel, have done vacuum harden treatment and deeply cold treatment to HRC50~55 before doing the grinding process, the essence is not easy to deformed.
- ▶ Parallelism Within 0.003/100mm
- ▶ Squareness Within 0.005/100mm
- ▶ Clamping range Maximum opening 155mm, opening depth 49.85mm
- ▶ Accessories T hex wrench x 1 pc
- ▶ Net weight 4.7KG
- ▶ Note Red mark is forbidden to disassemble

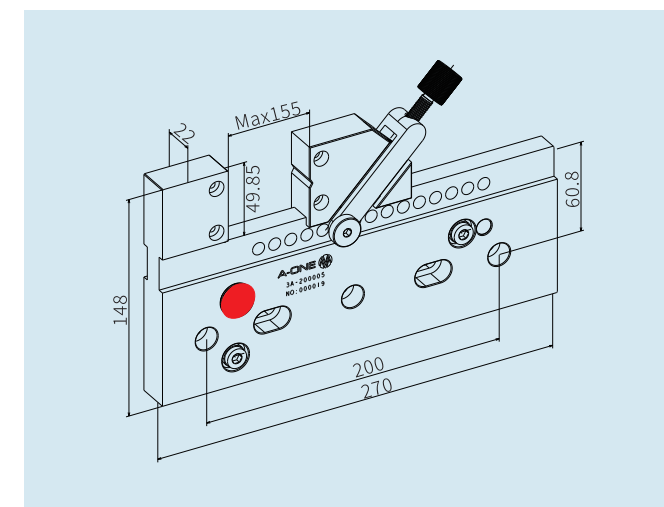

3A-200008 线割批士
Wire-cut vise

- ▶ 特点 材质采用高级不锈钢, 真空热处理后经深冷处理至硬度HRC50~55再进行研磨加工, 因此本体不易变形。
- ▶ 应用 适用于线切割机, 直接安装在工作台上
- ▶ 平行精度 0.003/100mm以内
- ▶ 垂直精度 0.005/100mm以内
- ▶ 适合夹持 圆形工件
- ▶ 夹持范围 最大夹持范围Φ45
- ▶ 最大负载 2.5KG
- ▶ 净重 3KG
- ▶ Characteristics The material is stainless steel, have done vacuum harden treatment and deeply cold treatment to HRC50~55 before doing the grinding process, the essence is not easy to deformed.
- ▶ Parallelism Within 0.003/100mm
- ▶ Squareness Within 0.005/100mm
- ▶ Suitable for clamping Round shape workpiece
- ▶ Clamping range MaxΦ45
- ▶ Load Max 2.5KG
- ▶ Net weight 3KG

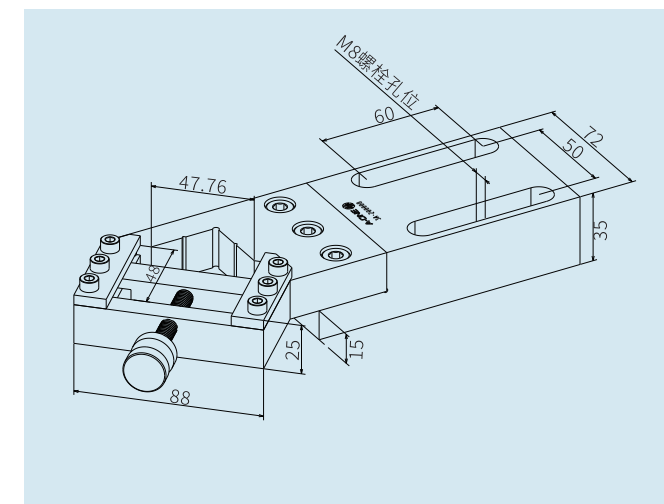

3A-200009 线割批士
Wire-cut vise

- ▶ 特点 材质采用高级不锈钢, 真空热处理后经深冷处理至硬度HRC50~55再进行研磨加工, 因此本体不易变形。
- ▶ 平行精度 0.003/100mm以内
- ▶ 垂直精度 0.005/100mm以内
- ▶ 夹持范围 最大开口84mm, 开口深度23mm
- ▶ 最大负载 2.5KG
- ▶ 净重 1.7KG
- ▶ Characteristics The material is stainless steel, have done vacuum harden treatment and deeply cold treatment to HRC50~55 before doing the grinding process, the essence is not easy to deformed.
- ▶ Parallelism Within 0.003/100mm
- ▶ Squareness Within 0.005/100mm
- ▶ Clamping range Max opening 84mm, opening depth 23mm
- ▶ Load Max 2.5KG
- ▶ Net weight 1.7KG

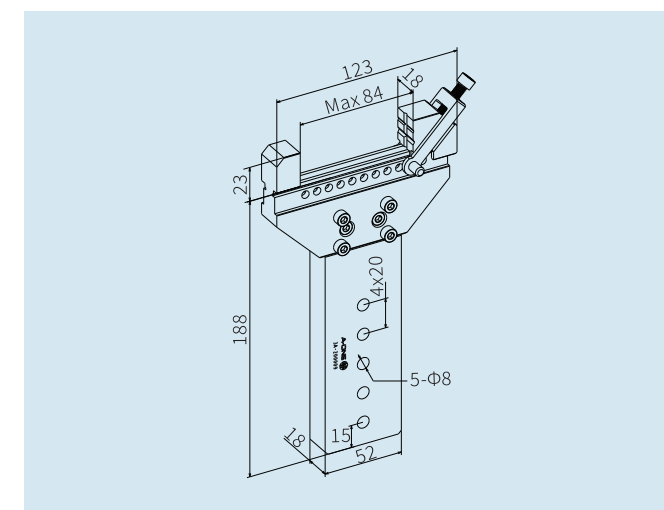

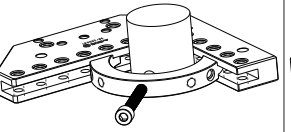
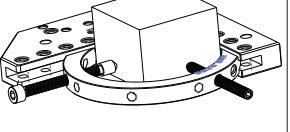
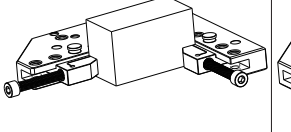
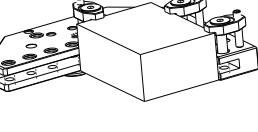
装夹示意图 Clamping sketch				
最大夹持尺寸 Maximum clamping size	Φ51*50	70*70*50	122*82*50	138*98*38
最大负载 Maximum Load	0.8kg	1.9kg	3.9kg	4kg

3A-200055 扁平批士 PalletSet W
Flat vise 8mm PalletSet W

- ▶ **规格** 一个可移动夹爪和一个固定式夹爪。硬质，磨削，耐腐蚀
- ▶ **夹持** 0-100 mm
- ▶ **最大负载** 5KG
- ▶ **应用** 侧面夹持尺寸0-100 mm的工件。适用于固定式夹头或摆动式夹头
- ▶ **净重** 1.2KG
- ▶ **Version** One movable jaw and one fixed jaw. Hardened, ground and corrosion-resistant
- ▶ **Clamping range** 0-100 mm
- ▶ **Load** Max 5KG
- ▶ **Application** Lateral clamping of workpieces machined outside of up to 100mm. To be fitted to fixed holder or pendulum holder
- ▶ **Net weight** 1.2KG

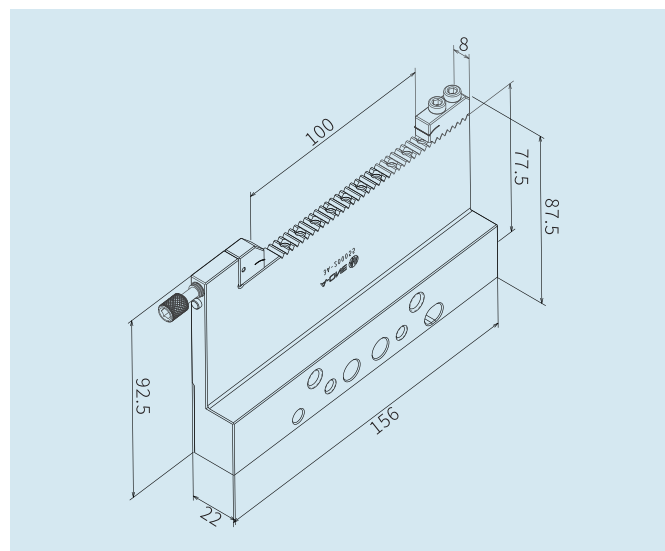

3A-210006 手动慢走丝批士
Manual walking wire clamp (vise)

- ▶ **特点** 材质采用高级不锈钢，真空热处理后经深冷处理至硬度HRC50~55再进行研磨加工，因此本体不易变形。特殊结构设计，夹持精度高
- ▶ **应用** 适用于各种线割机床上的工件夹持，主体可以微调，操作方便灵活。
- ▶ **平行精度** 0.003/100mm以内
- ▶ **垂直精度** 0.005/100mm以内
- ▶ **Characteristics** The material is stainless steel, have done vacuum harden treatment and deeply cold treatment to HRC50~55 before doing the grinding process, the essence is not easy to deformed. Special structural design for high clamping accuracy.
- ▶ **Application** Suitable for workpiece clamping on various wire cutting machines. Precise adjustable in mainbody, easy and flexible in operation
- ▶ **Parallelism** Within 0.003/100mm
- ▶ **Squareness** Within 0.005/100mm

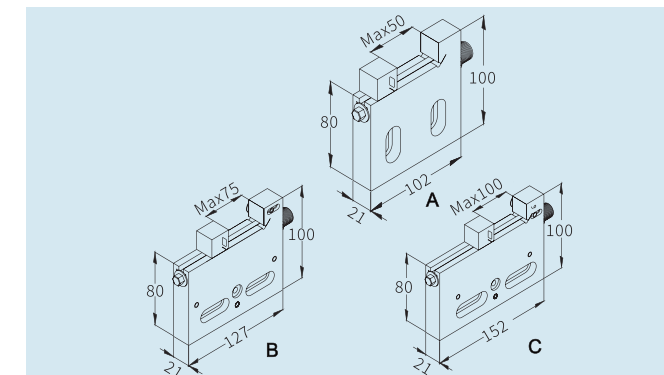

规格 Model	外形尺寸(mm) Dimensions	夹持范围(mm) Clamping range		重量(kg) Weight
		最大开口 Maximum opening	开口深度 Opening depth	
A	102x21x100	50	20	1.1
B	127x21x100	75	20	1.8
C	152x21x100	100	28	2.0

3A-210001 手动超薄慢走丝批士
Manual ultra-thin walking wire clamp

- ▶ **特点** 材质采用高级不锈钢，真空热处理后经深冷处理至硬度HRC50~55再进行研磨加工，因此本体不易变形。
- ▶ **平行精度** 0.003/100mm以内
- ▶ **垂直精度** 0.005/100mm以内
- ▶ **夹持范围** 最大开口75mm
- ▶ **净重** 1.7KG
- ▶ **Characteristics** The material is stainless steel, have done vacuum harden treatment and deeply cold treatment to HRC50~55 before doing the grinding process, the essence is not easy to deformed.
- ▶ **Parallelism** Within 0.003/100mm
- ▶ **Squareness** Within 0.005/100mm
- ▶ **Clamping range** Maximum opening 75mm
- ▶ **Net weight** 1.7KG

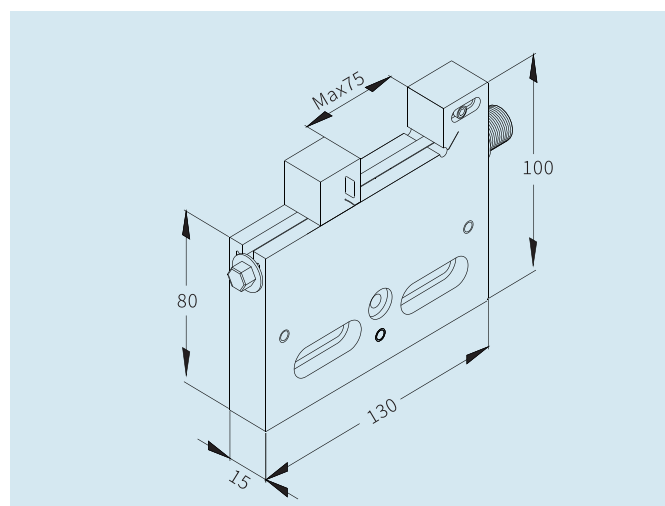

3A-210020 标配可调组合线切割批士
Precision combination wire-cut vise with adjustment function

- ▶ **特点** 材质采用高级不锈钢，真空热处理后经深冷处理至硬度HRC50~55再进行研磨加工，因此本体不易变形。本体具有水平、平行X、Y、Z轴微调功能。夹持力特别强，可挡高压冲水的压力。
- ▶ **平行精度** 0.003/100mm以内
- ▶ **垂直精度** 0.005/100mm以内
- ▶ **夹持范围** 最大开口160mm
- ▶ **净重** 7.8KG
- ▶ **注意** 红色标记禁止拆装 标准如右图
- ▶ **Characteristics** The material is stainless steel, have done vacuum harden treatment and deeply cold treatment to HRC50~55 before doing the grinding process, the essence is not easy to deformed. The vise is precise adjustable in horizontal, parallel and X, Y, Z axis. Strong clamping force can stand high water pressure.
- ▶ **Parallelism** Within 0.003/100mm
- ▶ **Squareness** Within 0.005/100mm
- ▶ **Clamping range** Maximum opening 160mm
- ▶ **Net weight** 7.8KG
- ▶ **Note** Red mark is forbidden to disassemble Standard as shown in the right figure

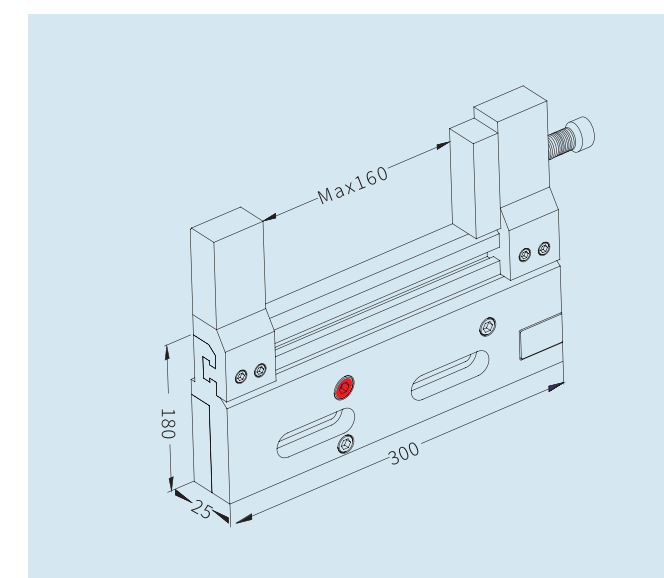

3A-210002 超薄慢走丝批士
Ultra-thin walking wire clamp

- ▶ **特点** 材质采用高级不锈钢，真空热处理后经深冷处理至硬度HRC50~55再进行研磨加工，因此本体不易变形。主体可微调，操作方便灵活
- ▶ **平行精度** 0.003/100mm以内
- ▶ **垂直精度** 0.005/100mm以内
- ▶ **夹持范围** 最大开口75mm
- ▶ **净重** 1KG
- ▶ **Characteristics** The material is stainless steel, have done vacuum harden treatment and deeply cold treatment to HRC50~55 before doing the grinding process, the essence is not easy to deformed. Precise adjustable in mainbody, easy and flexible in operation.
- ▶ **Parallelism** Within 0.003/100mm
- ▶ **Squareness** Within 0.005/100mm
- ▶ **Clamping range** Maximum opening 75mm
- ▶ **Net weight** 1KG

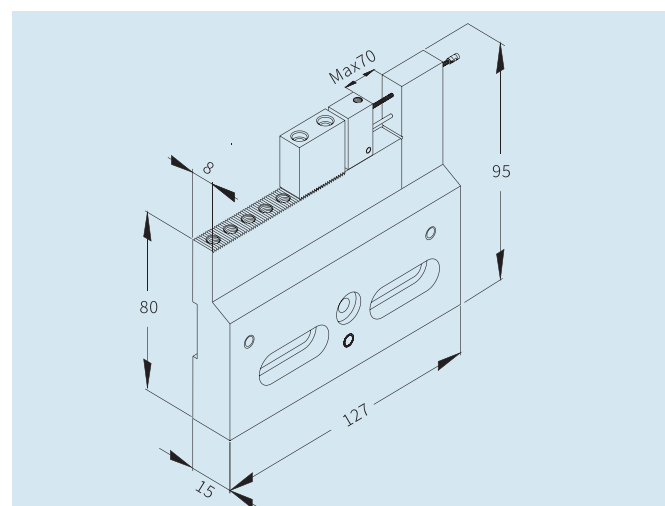

选配附件，价格另计
Optional accessories, price to be included separately

V型钳3A-210041 适配3A-210020 (如右图)
Adapt to 3A-210020 (as shown in the right figure)

压板钳3A-210042 适配3A-210020 (如右图)
Adapt to 3A-210020 (as shown in the right figure)

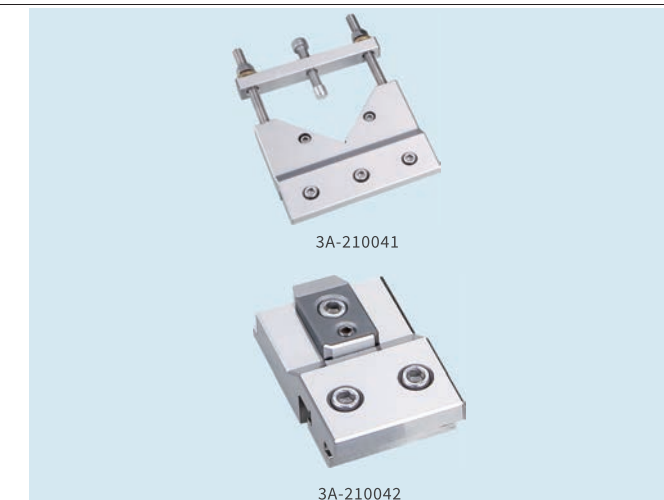

3A-210003 手动慢走丝批士
Manual walking wire clamp (vise)

- ▶ **特点** 材质采用高级不锈钢,真空热处理后经深冷处理至硬度HRC50~55再进行研磨加工,因此本体不易变形。
- ▶ **平行精度** 0.003/100mm以内
- ▶ **垂直精度** 0.005/100mm以内
- ▶ **Characteristics** The material is stainless steel, have done vacuum harden treatment and deeply cold treatment to HRC50~55 before doing the grinding process, the essence is not easy to deformed.
- ▶ **Parallelism** Within 0.003/100mm
- ▶ **Squareness** Within 0.005/100mm

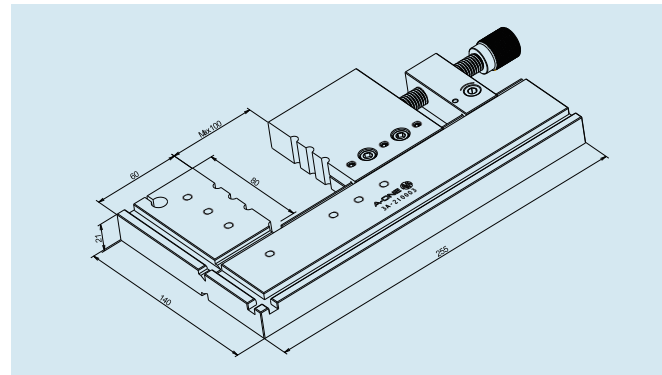

编号 Model No.	外形尺寸(mm) Dimensions	夹持范围(mm) Clamping range		重量(kg) Weight
		最大开口 Maximum opening	开口深度 Opening depth	
3A-210003	255x140x21	100	80	4.1

3A-210010 手动线切割批士
Manual wire edm vise

- ▶ **特点** 材质采用高级不锈钢,真空热处理后经深冷处理至硬度HRC50~55再进行研磨加工,因此本体不易变形。钳口开闭采用手转型夹持设计,可任意的旋转把手,调整至您所需的夹持工件大小,夹持工件方便快捷
- ▶ **平行精度** 0.003/100mm以内
- ▶ **垂直精度** 0.005/100mm以内
- ▶ **注意** 产品红色标识禁止拆装
- ▶ **Characteristics** Precision Vise of Stainless Steel for EDM,the material is stainless steel, have done vacuum harden treatment and deeply cold treatment to HRC50~55 before doing the grinding process, the essence is not easy to deformed. The jaw opening and closing adopts the hand-transformation clamping design, which can rotate the handle arbitrarily, adjust to the size of the clamping workpiece you need, and it is convenient to clamp the workpiece.
- ▶ **Parallelism** Within 0.003/100mm
- ▶ **Squareness** Within 0.005/100mm
- ▶ **Note** Red mark is forbidden to disassemble

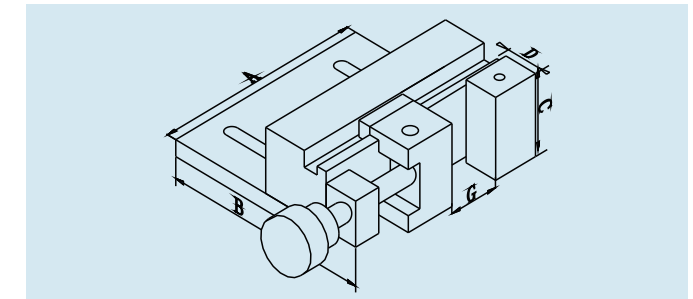

尺寸Size(mm)	型号 Model	25	30
A		175	185
B		140	140
C		54	70
D		30	35
G(max)		82	100
重量 Weight(kg)		3.7	6.7
最大负载 Max. Load(Kg)		5	8

3A-210008 手动慢走丝批士
Manual walking wire clamp (vise)

- ▶ **特点** 材质采用高级不锈钢,真空热处理后经深冷处理至硬度HRC50~55再进行研磨加工,因此本体不易变形。钳口开闭采用手转型夹持设计,可任意的旋转把手,调整至您所需的夹持工件大小,夹持工件方便快捷
- ▶ **平行精度** 0.003/100mm以内
- ▶ **垂直精度** 0.005/100mm以内
- ▶ **Characteristics** The material is stainless steel, have done vacuum harden treatment and deeply cold treatment to HRC50~55 before doing the grinding process, the essence is not easy to deformed. The jaw opening and closing adopts the hand-transformation clamping design, which can rotate the handle arbitrarily, adjust to the size of the clamping workpiece you need, and it is convenient to clamp the workpiece.
- ▶ **Parallelism** Within 0.003/100mm
- ▶ **Squareness** Within 0.005/100mm

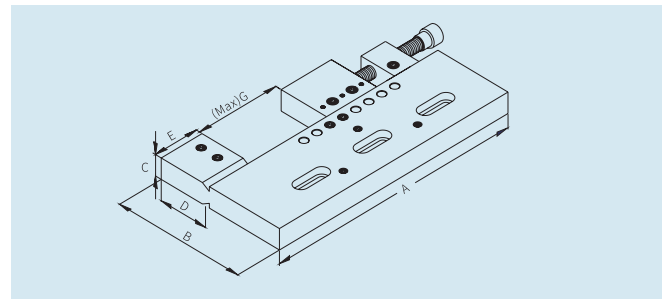

尺寸Size(mm)	型号 Model	100	150
A		247	320
B		145	145
C		22	22
D		50	60
E		60	60
G(max)		100	150
重量 Weight(kg)		4.5	6
最大负载 Max. Load(Kg)		8	10

3A-200016/17/18/19 不锈钢工具批士
Stainless steel vise

- ▶ **特点** 材质采用高级不锈钢,真空热处理后经深冷处理至硬度HRC50~55再进行研磨加工,因此本体不易变形。
- ▶ **平行精度** 0.003/100mm以内
- ▶ **垂直精度** 0.005/100mm以内
- ▶ **Characteristics** the material is stainless steel, have done vacuum harden treatment and deeply cold treatment to HRC50~55 before doing the grinding process, the essence is not easy to deformed.
- ▶ **Parallelism** Within 0.003/100mm
- ▶ **Squareness** Within 0.005/100mm

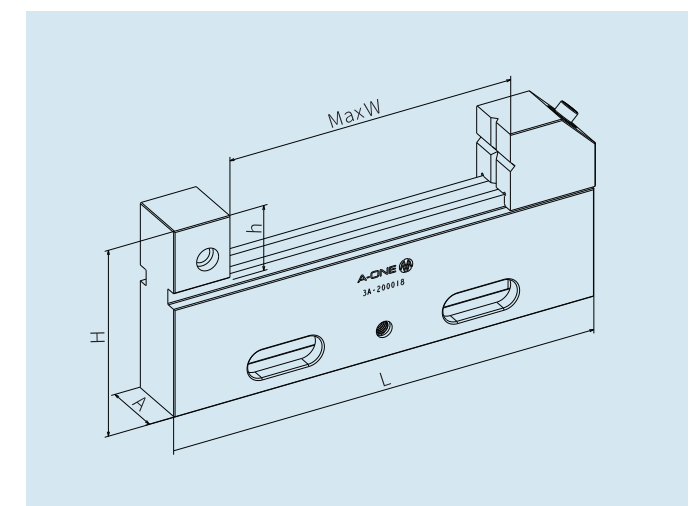

编号 Model No.	外形尺寸(mm) Dimensions	夹持范围(mm) Clamping range		重量(kg) Weight
		最大开口 Maximum opening	开口深度 Opening depth	
3A-200016	120x31.5x85	50	30	1.1
3A-200017	170x31.5x90	100	30	1.7
3A-200018	226x32x100	150	35	2.6
3A-200019	300x35.5x100	214	40	3.4

3A-210016 精密线割批士
Precision wire-cut vise

- ▶ **特点** 材质采用高级不锈钢,真空热处理后经深冷处理至硬度HRC50~55再进行研磨加工,因此本体不易变形。
- ▶ **应用** 钳口开闭采用手转型夹持设计,可任意的旋转把手,调整至您所需的夹持工件大小,夹持工件迅速方便
- ▶ **平行精度** 0.003/100mm以内
- ▶ **垂直精度** 0.005/100mm以内
- ▶ **注意** 产品红色标识禁止拆装
- ▶ **Characteristics** The material is stainless steel, have done vacuum harden treatment and deeply cold treatment to HRC50~55 before doing the grinding process, the essence is not easy to deformed.
- ▶ **Application** The jaw opening and closing adopts the hand-transformation clamping design, which can rotate the handle arbitrarily, adjust to the size of the clamping workpiece you need, and it is convenient to clamp the workpiece.
- ▶ **Parallelism** Within 0.003/100mm
- ▶ **Squareness** Within 0.005/100mm
- ▶ **Note** Red mark is forbidden to disassemble

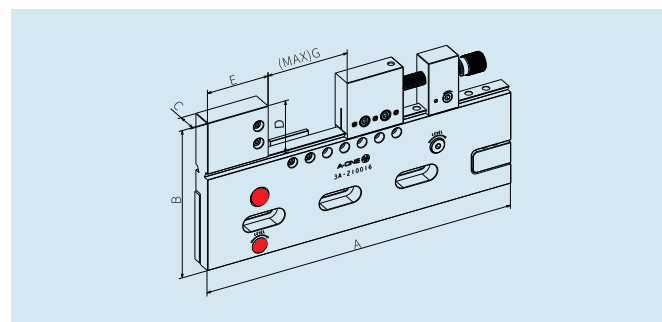

尺寸Size(mm)	型号 Model	100	160
A		249	350
B		160	170
C		24	24
D		50	60
E		50	60
G(max)		100	160
重量 Weight(kg)		4.8	7
最大负载 Max. Load(Kg)		6	10

3A-210012 精密线切割批士
Precision wire cut vise

- ▶ **特点** 材质采用高级不锈钢,真空热处理后经深冷处理至硬度HRC50~55再进行研磨加工,因此本体不易变形。
- ▶ **应用** 特殊结构设计,夹持精度高。钳口开闭采用手动螺杆式设计,较适合于小型工件的夹持
- ▶ **平行精度** 0.003/100mm以内
- ▶ **垂直精度** 0.005/100mm以内
- ▶ **夹持范围** 最大开口150mm,开口深度30mm
- ▶ **最大负载** 8KG
- ▶ **净重** 2.8KG
- ▶ **Characteristics** The material is stainless steel, have done vacuum harden treatment and deeply cold treatment to HRC50~55 before doing the grinding process, the essence is not easy to deformed. Special structural design for high clamping accuracy. The jaw opening is designed with a manual screw, suitable for small workpiece clamping.
- ▶ **Application** The jaw opening is designed with a manual screw, suitable for small workpiece clamping.
- ▶ **Parallelism** Within 0.003/100mm
- ▶ **Squareness** Within 0.005/100mm
- ▶ **Clamping range** Maximum opening 150mm, opening depth 30mm
- ▶ **Load** Max 8KG
- ▶ **Net weight** 2.8KG

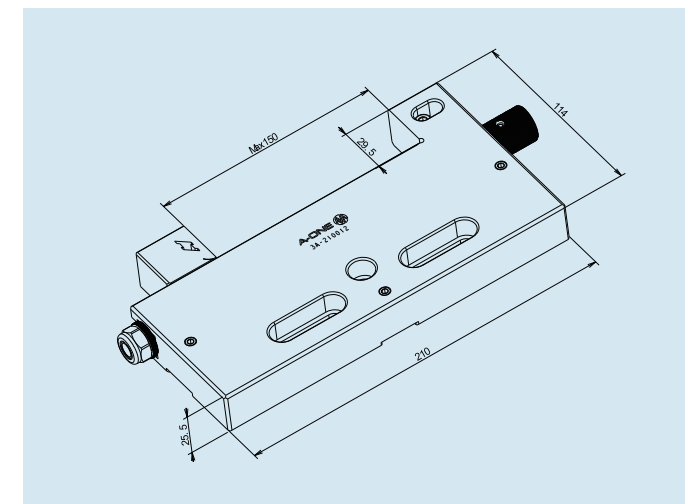

3A-210007 强力慢走丝批士
Power walking wire clamp (vise)

- ▶ **特点** 材质采用高级不锈钢,真空热处理后经深冷处理至硬度HRC50~55再进行研磨加工,因此本体不易变形。特殊结构设计,夹持精度高
- ▶ **应用** 适用于各种线切割机上的工件夹持,主体可以微调,操作方便灵活。
- ▶ **平行精度** 0.003/100mm以内
- ▶ **垂直精度** 0.005/100mm以内
- ▶ **Characteristics** The material is stainless steel, have done vacuum harden treatment and deeply cold treatment to HRC50~55 before doing the grinding process, the essence is not easy to deformed. Special structural design for high clamping accuracy
- ▶ **Application** Suitable for workpiece clamping on various wire cutting machines. Precise adjustable in mainbody, easy and flexible in operation
- ▶ **Parallelism** Within 0.003/100mm
- ▶ **Squareness** Within 0.005/100mm

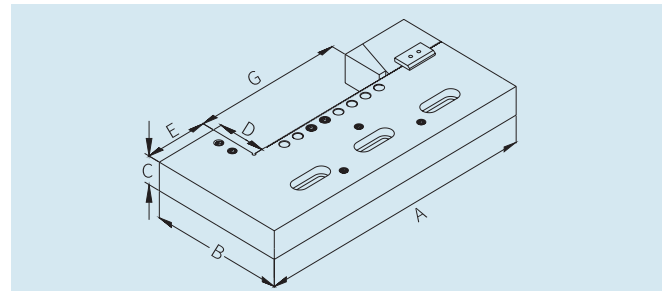

尺寸Size(mm)	型号 Model	100	150
A		270	320
B		135	135
C		22	22
D		50	50
E		50	75
G(max)		100	150
重量 Weight(kg)		4	5.5
最大负载 Max. Load(Kg)		10	12

3A-210015 微调式批士
Fine adjusting vise

- ▶ **特点** 材质采用高级不锈钢,真空热处理后经深冷处理至硬度HRC50~55再进行研磨加工,因此本体不易变形。钳口采用斜楔夹持方式,不会出现工件上浮的现象。本体可上下、左右、前后调整水平。夹持力特别强,可挡高压冲水的压力。
- ▶ **平行精度** 0.003/100mm以内
- ▶ **垂直精度** 0.005/100mm以内
- ▶ **注意** 产品红色标识禁止拆装
- ▶ **Characteristics** The material is stainless steel, have done vacuum harden treatment and deeply cold treatment to HRC50~55 before doing the grinding process, the essence is not easy to deformed. The jaws are clamped by a wedge, so that the workpiece does not float. The vise can be adjusted up and down, left and right, forth and back to make parallelism. Strong clamping force can stand high water pressure.
- ▶ **Parallelism** Within 0.003/100mm
- ▶ **Squareness** Within 0.005/100mm
- ▶ **Note** Red mark is forbidden to disassemble

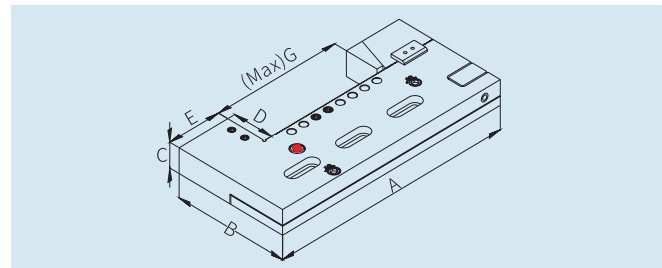

尺寸Size(mm)	型号 Model	100	160
A		270	350
B		170	170
C		24	24
D		50	60
E		60	80
G(max)		100	160
重量 Weight(kg)		5.4	7.8
最大负载 Max. Load(Kg)		6	10

3A-210019 可调线切割批士
Precision wire cut vise

- ▶ **特点** 材质采用高级不锈钢,真空热处理后经深冷处理至硬度HRC50~55再进行研磨加工,因此本体不易变形。本体具有水平、平行X、Y、Z轴微调功能。上盖放松螺丝后可快速移动前后采用特殊的斜角设计,夹持力强
- ▶ **平行精度** 0.003/100mm以内
- ▶ **垂直精度** 0.005/100mm以内
- ▶ **注意** 红色标识禁止拆装
- ▶ **Characteristics** The material is stainless steel, have done vacuum harden treatment and deeply cold treatment to HRC50~55 before doing the grinding process, the essence is not easy to deformed. The vise is precise adjustable in horizontal, parallel and X, Y, Z axis. The cover can be moved quickly back and forth after it is loosened. Special bevel design for strong clamping force
- ▶ **Parallelism** Within 0.003/100mm
- ▶ **Squareness** Within 0.005/100mm
- ▶ **Note** Red mark is forbidden to disassemble

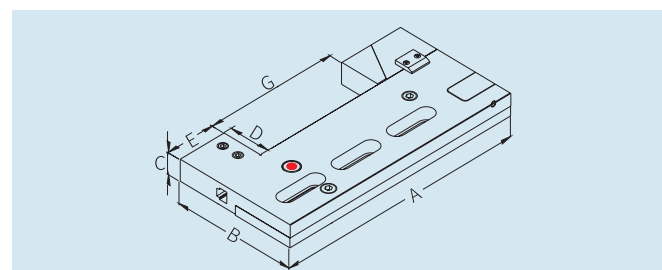

尺寸Size(mm)	型号 Model	100	160
A		240	300
B		160	160
C		24	24
D		50	50
E		60	60
G(max)		100	160
重量 Weight(kg)		5.4	7.8
最大负载 Max. Load(Kg)		6	10

3A-210011 直角万力
Square vise

- ▶ **特点** 材质采用高级不锈钢,真空热处理后经深冷处理至硬度HRC50~55再进行研磨加工,因此本体不易变形。
- ▶ **平行精度** 0.003/100mm以内
- ▶ **垂直精度** 0.005/100mm以内
- ▶ **最大负载** 12KG
- ▶ **净重** 5.4KG
- ▶ **Characteristics** The material is stainless steel, have done vacuum harden treatment and deeply cold treatment to HRC50~55 before doing the grinding process, the essence is not easy to deformed.
- ▶ **Parallelism** Within 0.003/100mm
- ▶ **Squareness** Within 0.005/100mm
- ▶ **Load** Max 12KG
- ▶ **Net weight** 5.4KG

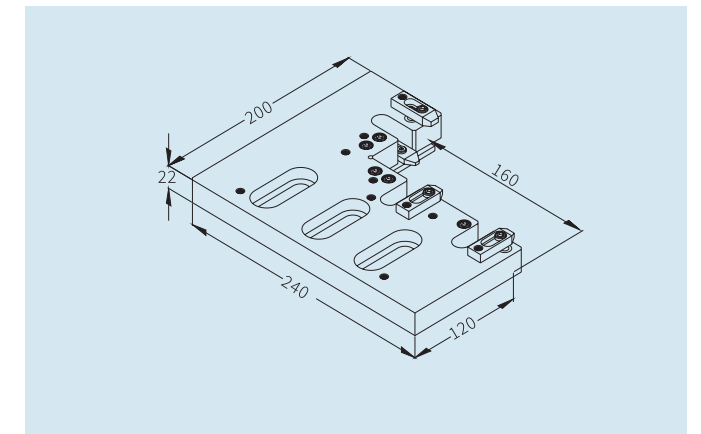

3A-210018 可调线切割批士
Precision wire cut pallet with adjustment function

- ▶ **特点** 材质采用高级不锈钢,真空热处理后经深冷处理至硬度HRC50~55再进行研磨加工,因此本体不易变形。本体具有水平、平行X、Y、Z轴微调功能。
- ▶ **平行精度** 0.003/100mm以内
- ▶ **垂直精度** 0.005/100mm以内
- ▶ **最大负载** 8KG
- ▶ **净重** 4.5KG
- ▶ **注意** 产品红色标识禁止拆装
- ▶ **Characteristics** The material is stainless steel, have done vacuum harden treatment and deeply cold treatment to HRC50~55 before doing the grinding process, the essence is not easy to deformed. The vise is precise adjustable in horizontal, parallel and X, Y, Z axis.
- ▶ **Parallelism** Within 0.003/100mm
- ▶ **Squareness** Within 0.005/100mm
- ▶ **Load** Max 8KG
- ▶ **Net weight** 4.5KG

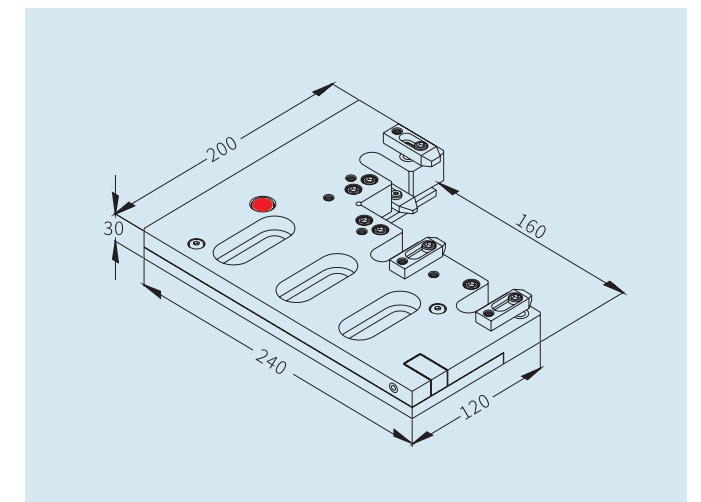

3A-210013 组合直角万力
Combination square vise of stainless steel

- ▶ **特点** 材质采用高级不锈钢,真空热处理后经深冷处理至硬度HRC50~55再进行研磨加工,因此本体不易变形。
- ▶ **应用** 适用于线切割机加工各种板类零件与圆形零件
- ▶ **平行精度** 0.003/100mm以内
- ▶ **垂直精度** 0.005/100mm以内
- ▶ **净重** 9KG
- ▶ **Characteristics** The material is stainless steel, have done vacuum harden treatment and deeply cold treatment to HRC50~55 before doing the grinding process, the essence is not easy to deformed.
- ▶ **Application** Suitable for wire cutting machine for processing all kinds of plate parts and round parts
- ▶ **Parallelism** Within 0.003/100mm
- ▶ **Squareness** Within 0.005/100mm
- ▶ **Net weight** 9KG

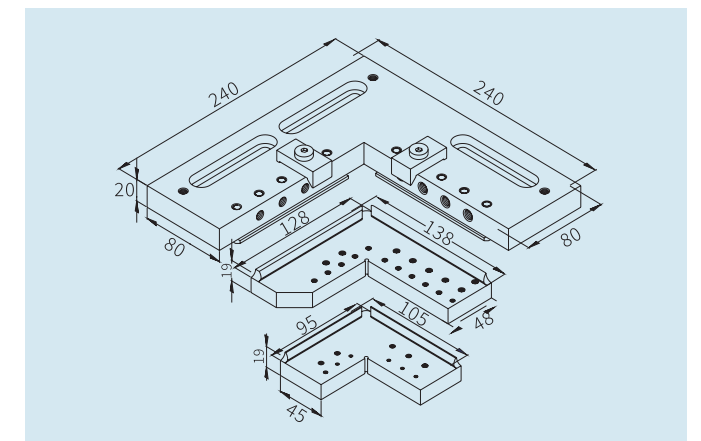

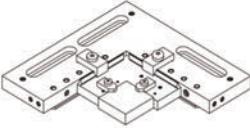
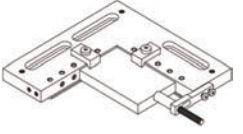
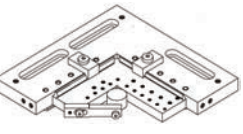
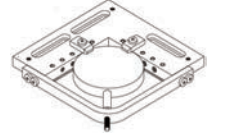
装夹示意图 Clamping sketch				
最大夹持尺寸 Maximum clamping size	48*48	150*150	Φ35	Φ150
最大负载 Maximum Load	2kg	5kg	2kg	5kg

3A-210021 水平调整式底座
Universal base of stainless steel

- ▶ **特点** 材质采用高级不锈钢, 真空热处理后经深冷处理至硬度HRC50~55再进行研磨加工, 因此本体不易变形。L型块以及用于薄型零件的钳口全部组装起来后, 可更有效地固定各种零件
- ▶ **净重** 19.2KG
- ▶ **Characteristics** The material is stainless steel, have done vacuum harden treatment and deeply cold treatment to HRC50~55 before doing the grinding process, the essence is not easy to deformed.
The L-block and the jaws for thin parts are all assembled to more effectively secure various parts.
- ▶ **Net weight** 19.2KG

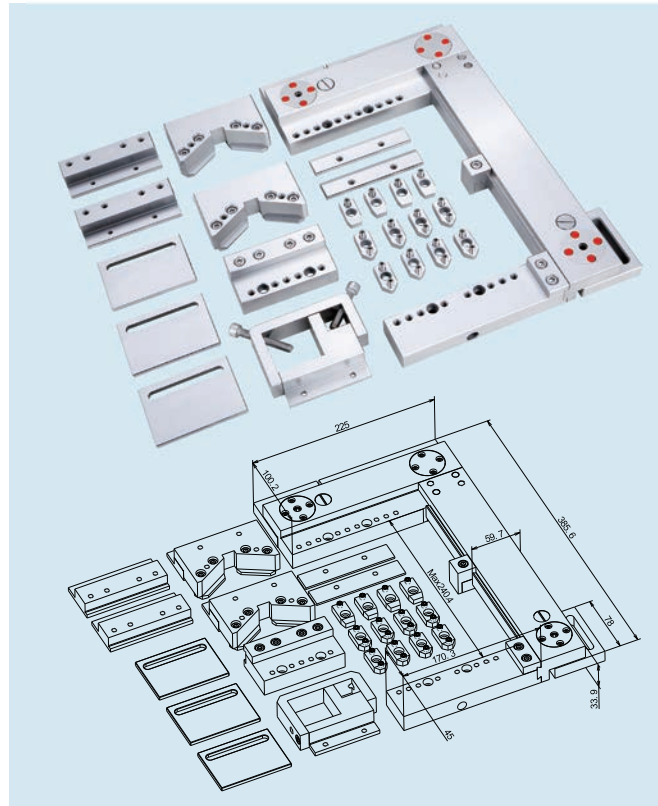

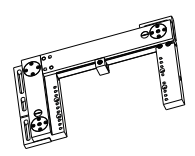
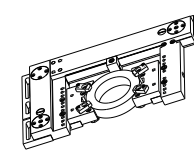
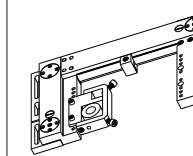
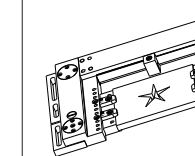
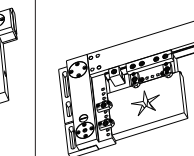
装夹示意图 Clamping sketch					
最大夹持尺寸 Maximum clamping size	270*160*40	Φ120*50	Φ40/Φ20*80	180*150*40	180*150*40
最大负载 Maximum Load	8kg	4.5kg	1kg	7.5kg	7.5kg

3A-200029/30 方型夹紧和件
Square support

- ▶ **特点** 材质采用高级不锈钢, 真空热处理后经深冷处理至硬度HRC50~55再进行研磨加工, 因此本体不易变形。
- ▶ **平行精度** 0.003/100mm以内
- ▶ **垂直精度** 0.005/100mm以内
- ▶ **Characteristics** The material is stainless steel, have done vacuum harden treatment and deeply cold treatment to HRC50~55 before doing the grinding process, the essence is not easy to deformed.
- ▶ **Parallelism** Within 0.003/100mm
- ▶ **Squareness** Within 0.005/100mm

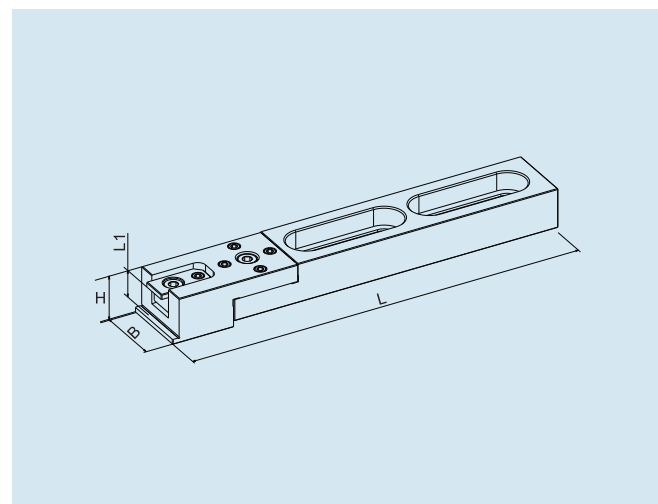

编号 Model No.	外形尺寸(mm) Dimensions	夹持范围(mm) Clamping range	重量(kg) Weight
3A-200029	200x40x30	5<L<50	1.60
3A-200030	300x50x40	50<L<100	2.54

3A-200033 圆形夹紧和件
Circular power clamp

- ▶ **特点** 材质采用高级不锈钢, 真空热处理后经深冷处理至硬度HRC50~55再进行研磨加工, 因此本体不易变形。
- ▶ **平行精度** 0.003/100mm以内
- ▶ **垂直精度** 0.005/100mm以内
- ▶ **Characteristics** The material is stainless steel, have done vacuum harden treatment and deeply cold treatment to HRC50~55 before doing the grinding process, the essence is not easy to deformed.
- ▶ **Parallelism** Within 0.003/100mm
- ▶ **Squareness** Within 0.005/100mm

编号 Model No.	ØD(mm)	重量(kg) Weight
3A-200033	10-50	1.8

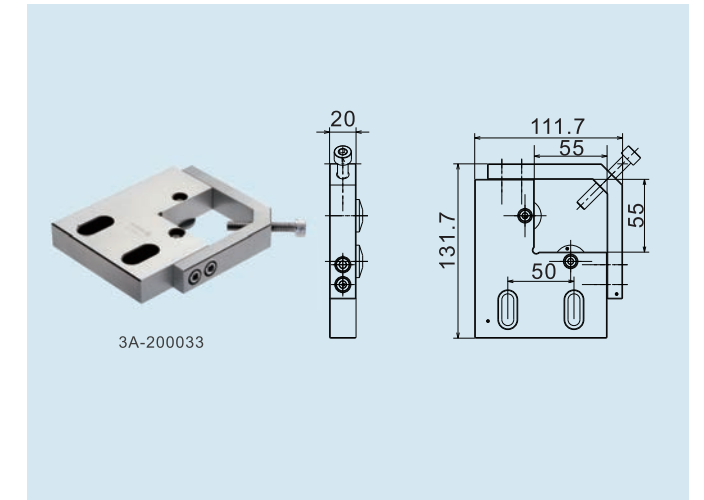

3A-200034 圆形夹紧和件
Circular power clamp

- ▶ **特点** 材质采用高级不锈钢, 真空热处理后经深冷处理至硬度HRC50~55再进行研磨加工, 因此本体不易变形。
- ▶ **平行精度** 0.003/100mm以内
- ▶ **垂直精度** 0.005/100mm以内
- ▶ **Characteristics** The material is stainless steel, have done vacuum harden treatment and deeply cold treatment to HRC50~55 before doing the grinding process, the essence is not easy to deformed.
- ▶ **Parallelism** Within 0.003/100mm
- ▶ **Squareness** Within 0.005/100mm

编号 Model No.	ØD(mm)	重量(kg) Weight
3A-200034	50-100	2

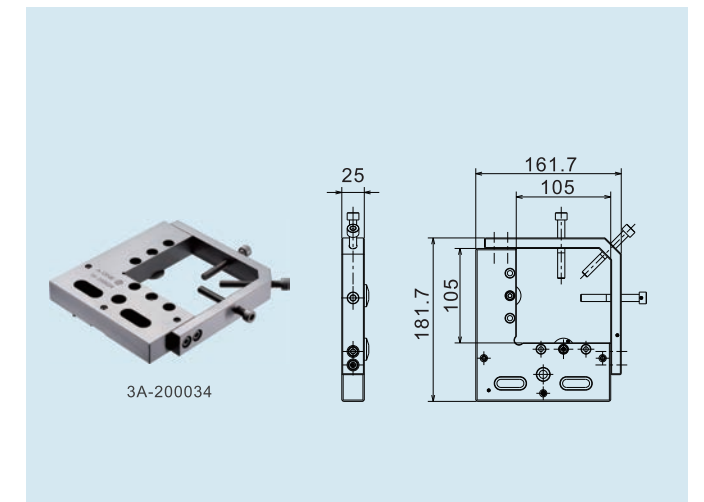

3A-200031/32 不锈钢压块
Stainless steel plate

- ▶ **特点** 材质采用高级不锈钢, 真空热处理后经深冷处理至硬度HRC50~55再进行研磨加工, 因此本体不易变形。
- ▶ **应用** 使用于铣床、磨床、电火花或线割机床
- ▶ **Characteristics** The material is stainless steel, have done vacuum harden treatment and deeply cold treatment to HRC50~55 before doing the grinding process, the essence is not easy to deformed.
- ▶ **Application** To be used on milling, grinding or EDM/WEDM machines

编号 Model No.	外形尺寸(mm) Dimensions	重量(kg) Weight
3A-200031	70x25x15	0.14
3A-200032	100x25x15	0.2

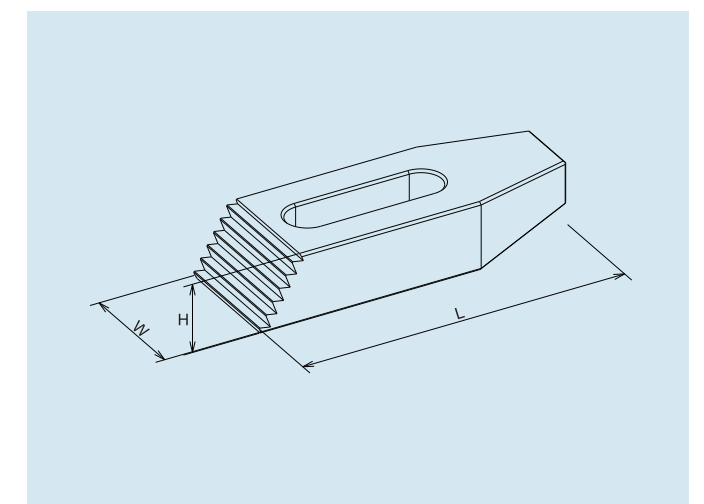

3A-200037/38/39 不锈钢角度垫块
Stainless steel angle block M

- ▶ **特点** 材质采用高级不锈钢, 真空热处理后经深冷处理至硬度HRC50~55再进行研磨加工, 因此本体不易变形。
- ▶ **应用** 使用于铣床、磨床、电火花或线切割机床
- ▶ **Characteristics** The material is stainless steel, have done vacuum harden treatment and deeply cold treatment to HRC50~55 before doing the grinding process, the essence is not easy to deformed.
- ▶ **Application** To be used on milling, grinding or EDM/WEDM machines

编号 Model No.	外形尺寸(mm) Dimensions	重量(kg) Weight
3A-200037	31x25x51	0.19
3A-200038	44x25x72	0.33
3A-200039	55x25x92	0.52

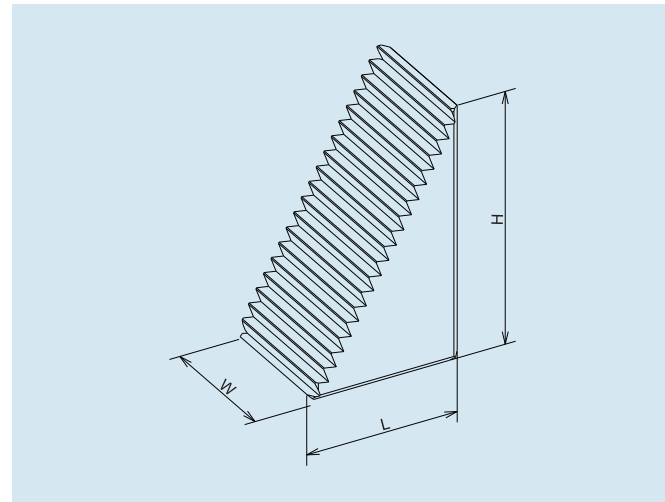

3A-210027 一目治具
Finger holder

- ▶ **特点** 材质采用高级不锈钢, 真空热处理后经深冷处理至硬度HRC50~55再进行研磨加工, 因此本体不易变形。可根据工件的类型组合使用, 适合任何品牌线切割机床使用。
- ▶ **应用** 0.003/100mm以内
- ▶ **平行精度** 0.003/100mm以内
- ▶ **垂直精度** 0.005/100mm以内
- ▶ **Characteristics** The material is stainless steel, have done vacuum harden treatment and deeply cold treatment to HRC50~55 before doing the grinding process, the essence is not easy to deformed.
- ▶ **Application** It can be combined according to the type of workpiece and is suitable for any brand of wire cutting machine.
- ▶ **Parallelism** Within 0.003/100mm
- ▶ **Squareness** Within 0.005/100mm

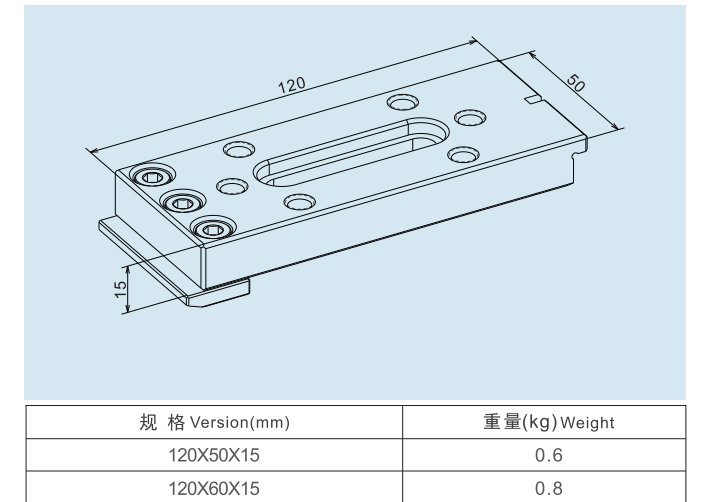

规格 Version(mm)	重量(kg) Weight
120X50X15	0.6
120X60X15	0.8
150X50X15	-
180X50X15	-

3A-210039 夹紧支承千斤顶
Stainless steel clamping Jack set

- ▶ **规格** 针对加工零件的厚度不同, 夹紧支承千斤顶可以灵活调节高度, 方便、稳定可靠
- ▶ **高度** 基础件A高度为30mm, 辅助件B的高度为15mm, 辅助件可叠加于基础件下, 每次增加高度为15mm, 高度H=30+15xN (N=辅助件B的个数)
- ▶ **Version** Height of clamping jack can be adjusted in terms of different thickness of machined parts, which is convenient and reliable
- ▶ **H** The height of the base part A is 30 mm, and auxiliary part B is 15 mm. The auxiliary part can be superimposed on the base part to increase the height, each time 15mm. H=30mm+15mm*N (N is the number of auxiliary part)

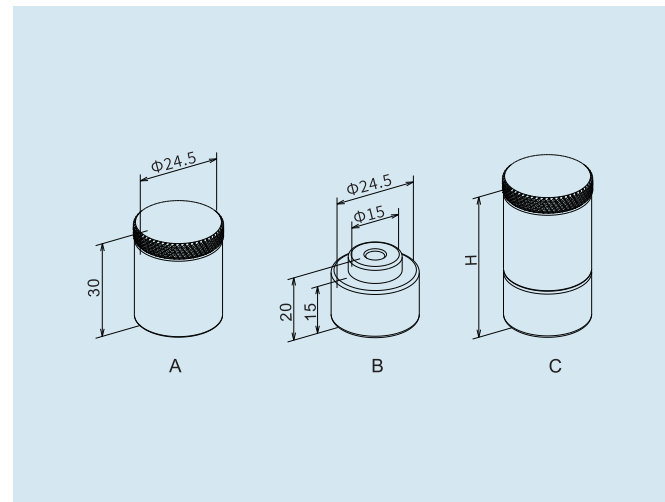

3A-210028 二目治具
Basic adapter

- ▶ **特点** 120X100X15mm 材质采用高级不锈钢, 真空热处理后经深冷处理至硬度HRC50~55再进行研磨加工, 因此本体不易变形。可根据工件的类型组合使用, 适合任何品牌线切割机床使用。
- ▶ **应用** 0.003/100mm以内
- ▶ **平行精度** 0.003/100mm以内
- ▶ **垂直精度** 0.005/100mm以内
- ▶ **最大负载** 20KG
- ▶ **净重** 1.2KG
- ▶ **Characteristics** 120X100X15mm The material is stainless steel, have done vacuum harden treatment and deeply cold treatment to HRC50~55 before doing the grinding process, the essence is not easy to deformed.
- ▶ **Application** It can be combined according to the type of workpiece and is suitable for any brand of wire cutting machine.
- ▶ **Parallelism** Within 0.003/100mm
- ▶ **Squareness** Within 0.005/100mm
- ▶ **Load** Max 20KG
- ▶ **Net weight** 1.2KG

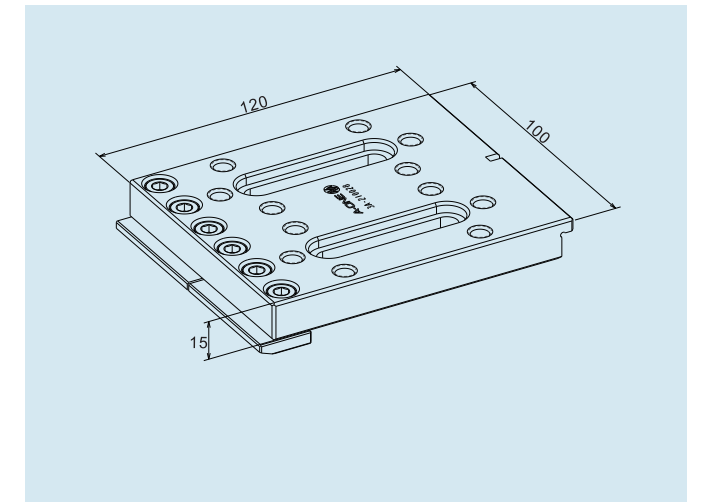

3A-210040 夹紧架高螺丝
Stainless steel clamping screw set

- ▶ **规格** 针对加工零件的厚度不同, 架高螺丝可以灵活调节高度, 方便、稳定可靠
- ▶ **高度** 25mm/30mm/35mm/40mm/45mm/50mm/55mm/60mm 65mm/70mm/75mm/80mm/85mm/90mm/95mm/100mm 105mm/110mm/115mm/120mm/125mm/130mm
- ▶ **Version** Height of clamping screw can be adjusted in terms of different thickness of machined parts, which is convenient and reliable
- ▶ **H** 25mm/30mm/35mm/40mm/45mm/50mm/55mm/60mm 65mm/70mm/75mm/80mm/85mm/90mm/95mm/100mm 105mm/110mm/115mm/120mm/125mm/130mm

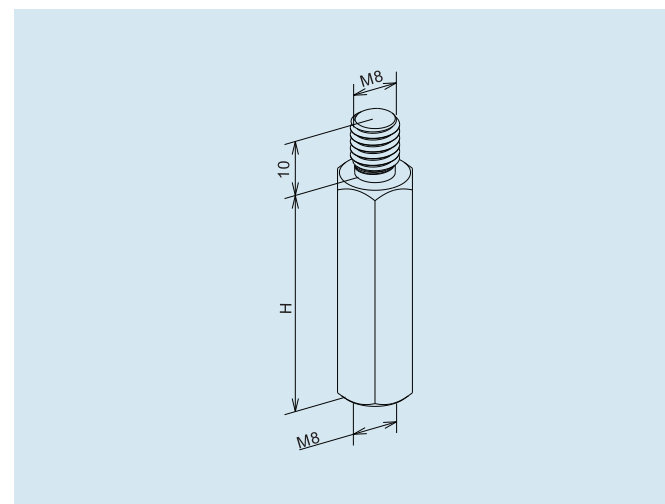

3A-210029 三目治具
Basic adapter

- ▶ **特点** 120X150X15mm 材质采用高级不锈钢, 真空热处理后经深冷处理至硬度HRC50~55再进行研磨加工, 因此本体不易变形。可根据工件的类型组合使用, 适合任何品牌线切割机床使用。
- ▶ **应用** 0.003/100mm以内
- ▶ **平行精度** 0.003/100mm以内
- ▶ **垂直精度** 0.005/100mm以内
- ▶ **最大负载** 20KG
- ▶ **净重** 1.9KG
- ▶ **Characteristics** 120X150X15mm The material is stainless steel, have done vacuum harden treatment and deeply cold treatment to HRC50~55 before doing the grinding process, the essence is not easy to deformed.
- ▶ **Application** It can be combined according to the type of workpiece and is suitable for any brand of wire cutting machine.
- ▶ **Parallelism** Within 0.003/100mm
- ▶ **Squareness** Within 0.005/100mm
- ▶ **Load** Max 20KG
- ▶ **Net weight** 1.9KG

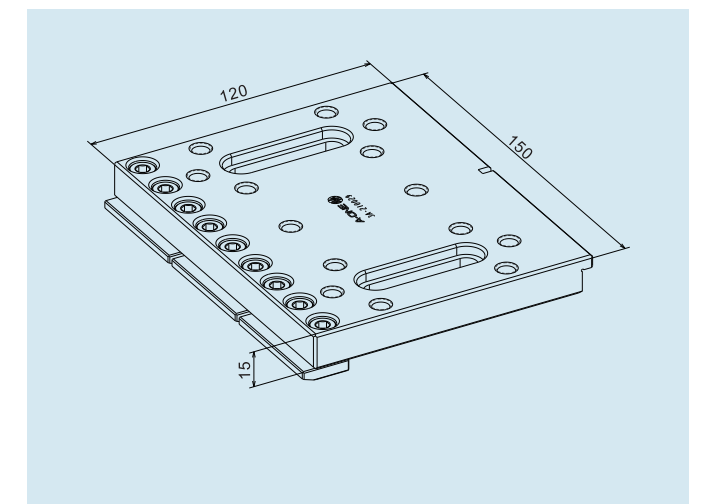

部分合作伙伴 (排序不分先后)

模具加工 Mold processing



零件加工 Parts processing



其他 Other



更多产品请咨询专业的客服

